

Confidential



# basic education

Department:  
Basic Education  
**REPUBLIC OF SOUTH AFRICA**

## **SENIOR CERTIFICATE EXAMINATIONS/ NATIONAL SENIOR CERTIFICATE EXAMINATIONS**

**TECHNICAL SCIENCES P2**

**MAY/JUNE 2025**

**MARKS: 75**

**TIME: 1½ hours**

**This question paper consists of 11 pages and 4 data sheets.**



**INSTRUCTIONS AND INFORMATION**

1. Write your centre number and examination number in the appropriate spaces on the ANSWER BOOK.
2. This question paper consists of SEVEN questions. Answer ALL the questions in the ANSWER BOOK.
3. Start EACH question on a NEW page in the ANSWER BOOK.
4. Number the answers correctly according to the numbering system used in this question paper.
5. Leave ONE line between two subquestions, e.g. between QUESTION 2.1 and QUESTION 2.2.
6. You may use a non-programmable calculator.
7. You are advised to use the attached DATA SHEETS.
8. Round off your FINAL numerical answers to a minimum of TWO decimal places.
9. Give brief motivations, discussions, etc. where required.
10. Write neatly and legibly.



**QUESTION 1: MULTIPLE-CHOICE QUESTIONS**

Various options are provided as possible answers to the following questions. Choose the answer and write only the letter (A–D) next to the question numbers (1.1 to 1.5) in the ANSWER BOOK, e.g. 1.6 D.

1.1 A molecular formula is described as a ...

- A formula of an organic compound that contains carbon and hydrogen atoms only.
- B formula of a compound that shows the number and the type of atoms within the compound.
- C condensed representation used to indicate the number of carbon atoms in a compound.
- D condensed representation used to indicate the number of hydrogen atoms in a compound.

(2)

1.2 The following represents an industrial process involving the manufacturing of margarine from unsaturated plant oils:

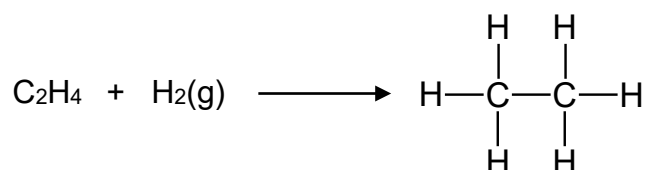

Which ONE of the combinations below CORRECTLY characterises the process in terms of reaction type and a suitable alternative name?

	REACTION TYPE	ALTERNATIVE NAME
A	Substitution	Hydrohalogenation
B	Elimination	Hydration
C	Addition	Halogenation
D	Addition	Hydrogenation

(2)

1.3 Which ONE of the following statements about semiconductors is TRUE?

Electrical conductivity ability ...

- A increases as temperature decreases.
- B decreases as temperature increases.
- C is between that of a conductor and an insulator.
- D is between that of a non-metal and an insulator.

(2)



1.4 Which ONE of the following reactions does NOT occur spontaneously?

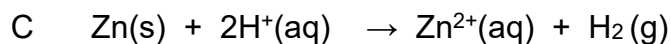
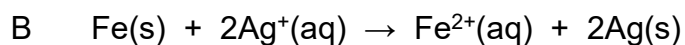
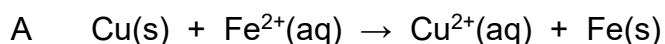

1.5 Consider the redox reaction:

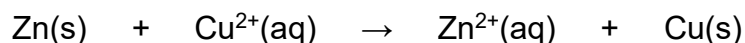

The CORRECT representation of the reduction half-reaction is expressed as ...

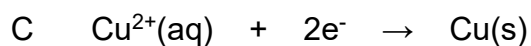
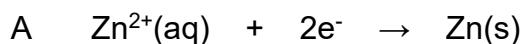

(2)  
[10]



**QUESTION 2 (Start on a new page.)**

Consider the following organic compounds:

<b>A</b>	
<b>B</b>	2-methylpropane
<b>C</b>	$\text{CH}_3(\text{CH}_2)_2\text{CH}_3$

- 2.1 Write down the IUPAC name for compound **A**. (2)
- 2.2 Define the term *structural isomer*. (2)
- 2.3 Identify the TWO compounds which are isomers. Write down ONLY the letters. (1)
- 2.4 Consider the IUPAC names of the following compounds:

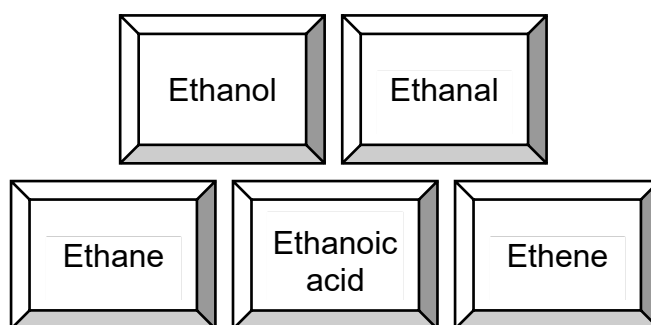

From the list above, write down the NAME of the compound representing EACH of the following:

- 2.4.1 An aldehyde (1)
- 2.4.2 Combustion of 2 moles of this compound in the presence of 7 moles of  $\text{O}_2$  forms 4 moles of  $\text{CO}_2$  and 6 moles  $\text{H}_2\text{O}$  (1)
- 2.4.3 Has a carboxyl group (1)



2.5 Ethene is used as a monomer in the preparation of polythene.

2.5.1 Define the term *monomer*. (2)

2.5.2 Name the process during which polythene is manufactured. (1)



2.5.3 Name ONE industrial use of polythene. (1)

[12]

### QUESTION 3 (Start on a new page.)

The table below shows some organic compounds that are commonly used in everyday life. Illuminating paraffin for domestic heating and lighting, petrol in automobiles and candle wax are products of crude oil.

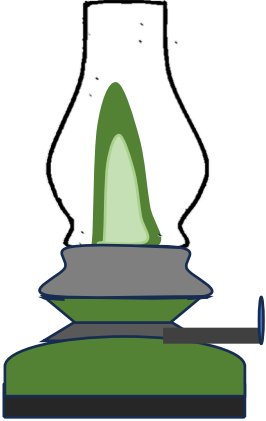
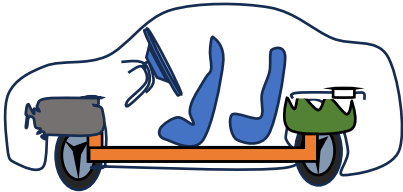
The general formula for these compounds is  $C_nH_{2n+2}$ .

 <p>Illuminating paraffin in lamps</p>	 <p>Petrol in cars</p>	 <p>Candle wax</p>
Boiling point: 150 °C–280 °C	Boiling point: 60 °C–90 °C	Boiling point: 370 °C

3.1 Consider the organic compounds represented in the table above.

3.1.1 Write down the name of the homologous series to which they belong. (1)

3.1.2 Draw the structural formula of their functional group. (1)

3.2 Identify the intermolecular forces present in these organic compounds. (1)

3.3 Which ONE of these compounds will have the highest viscosity? (1)

3.4 Which ONE of these compounds has the highest vapour pressure? Explain the answer. (3)

[7]



**QUESTION 4 (Start on a new page.)**

Study the flow diagram below of organic reactions.

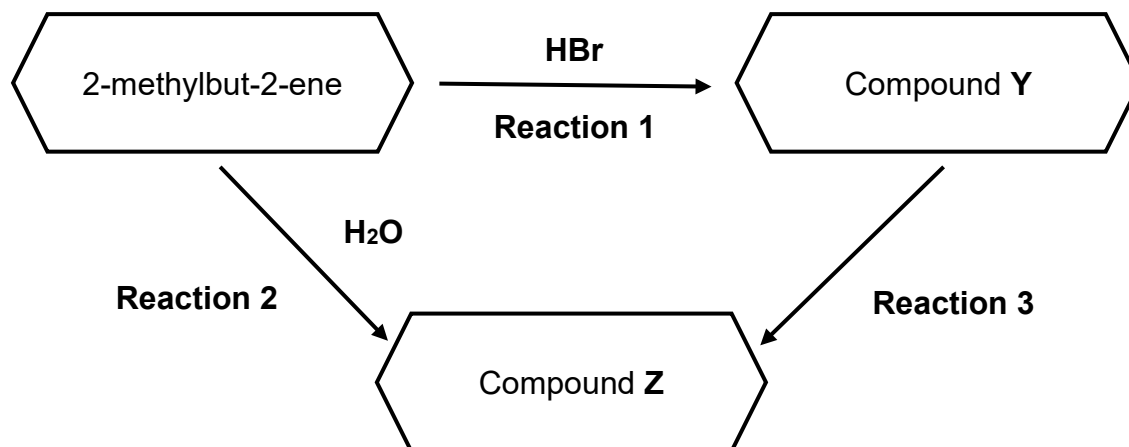

2-methylbut-2-ene appears as a clear colourless liquid with a petroleum-like odour. The diagram above shows how this compound can be converted to either a haloalkane or a tertiary alcohol.

4.1 What is meant by the term *tertiary alcohol*? (2)

4.2 Write down the:

4.2.1 MOLECULAR FORMULA of the organic reactant used in reaction 1 and 2 (1)

4.2.2 STRUCTURAL FORMULA of compound Y formed in reaction 1 (3)

4.2.3 IUPAC name of compound Z formed in reaction 2 (2)

Compound Z can also be formed from compound Y during reaction 3.

4.3 Name the TYPE of reaction represented by reaction 3. (1)

4.4 State TWO conditions needed for reaction 3. (2)

**[11]**



**QUESTION 5 (Start on a new page.)**

Study the diagram and the graph below carefully and answer the questions that follow.

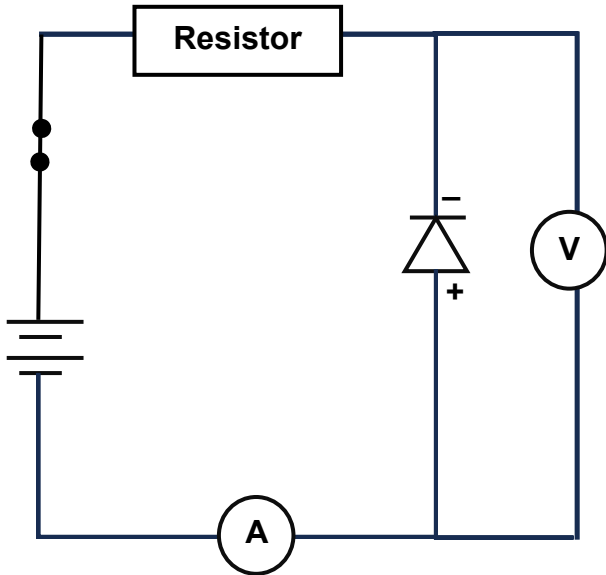

**Circuit diagram**

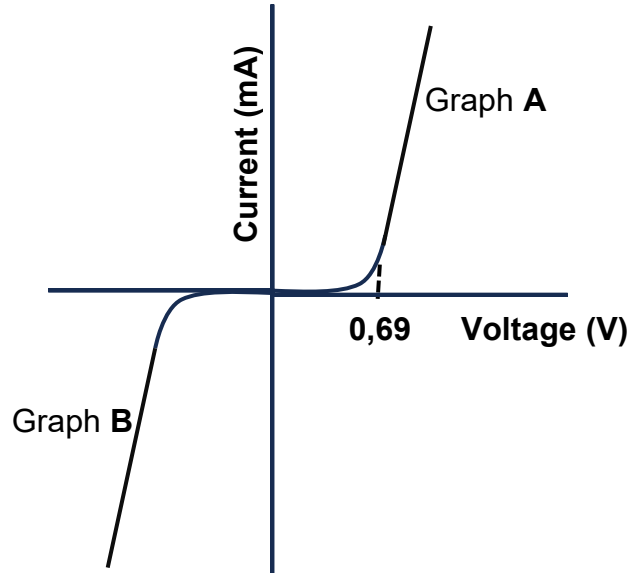

**Graphs of current versus voltage in a p-n junction diode**

- 5.1 Define the term *intrinsic semiconductor*. (2)
- 5.2 Give ONE example of an intrinsic semiconductor. (1)
- 5.3 What type of p-n junction diode is represented in the circuit diagram above? Write down only FORWARD BIASED, REVERSE BIASED or NON-BIASED. (1)
- 5.4 Explain the answer to QUESTION 5.3. (2)
- 5.5 Which ONE of the graphs describes the current-voltage characteristics of the p-n junction diode represented by the circuit diagram? Write down only Graph A or Graph B. (1)
- 5.6 Explain the characteristics of the p-n junction diode that is represented by Graph A when the applied voltage is increased. Refer to the RESISTANCE, the CURRENT flowing through it and the BREAK-DOWN VOLTAGE. (3)

**[10]**



**QUESTION 6 (Start on a new page.)**

Consider the electrolytic cell below and then answer the questions that follow.

Electrodes **M** and **N** are carbon rods.

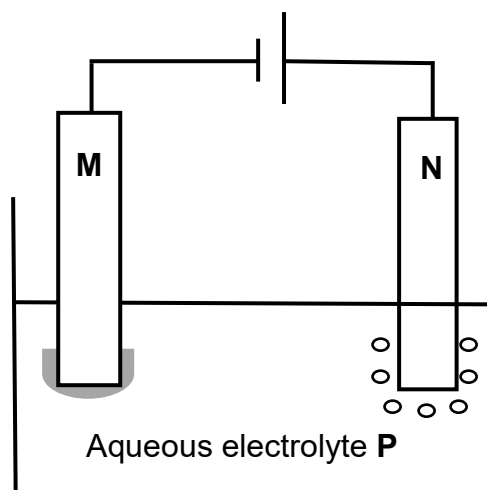

During electrolysis of aqueous electrolyte **P**, the following observations were made:

- Bubbles were formed around electrode **N**.
- A reddish-brown layer was formed on electrode **M**.
- The blue colour of electrolyte **P** became lighter.

- 6.1 Define the term *reduction*. (2)
- 6.2 Identify:
- 6.2.1 Electrolyte **P** (1)
- 6.2.2 The reddish-brown layer formed on electrode **M** (1)
- 6.2.3 The gas formed around electrode **N** (1)
- 6.2.4 The ion responsible for the blue colour of aqueous electrolyte **P** (1)
- 6.3 Write down the half-reaction that occurs at electrode **M**. (2)
- [8]**



**QUESTION 7 (Start on a new page.)**

The potential difference of a voltaic cell, measured experimentally by Technical Sciences learners, is COMPARED with its potential difference calculated under standard conditions.

The learners set up the voltaic cell, as shown below.

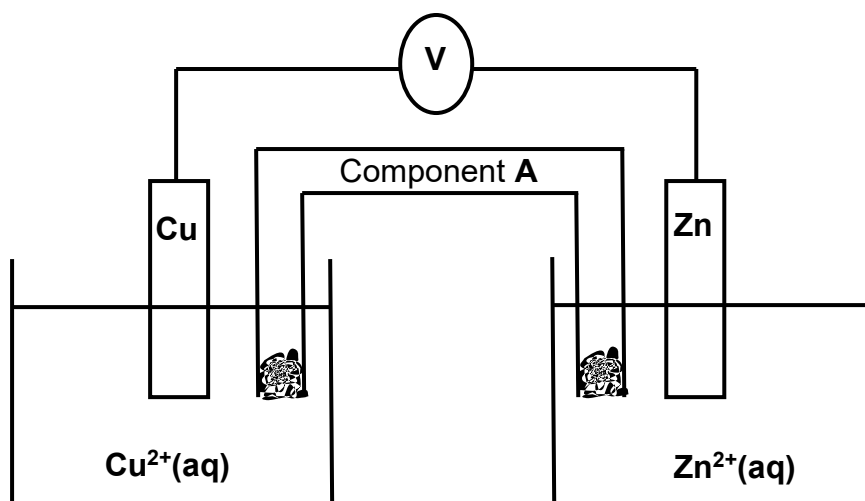

The voltmeter measures an initial reading of 0,9 V.

- 7.1 Define a *galvanic cell*. (2)
- 7.2 State TWO functions of component **A**. (2)
- 7.3 In which direction do electrons flow in the external circuit when this cell delivers current? Write down only **Cu to Zn** or **Zn to Cu**. (1)
- 7.4 Calculate the initial emf of the cell above under STANDARD CONDITIONS. (4)
- 7.5 From the results obtained, the learners conclude that the measured emf differs from the calculated emf.  
Give ONE possible reason for this difference in values. (2)



Study Diagrams **A** and **B** below, which illustrate how energy is derived from TWO different sources, and then answer the questions that follow.

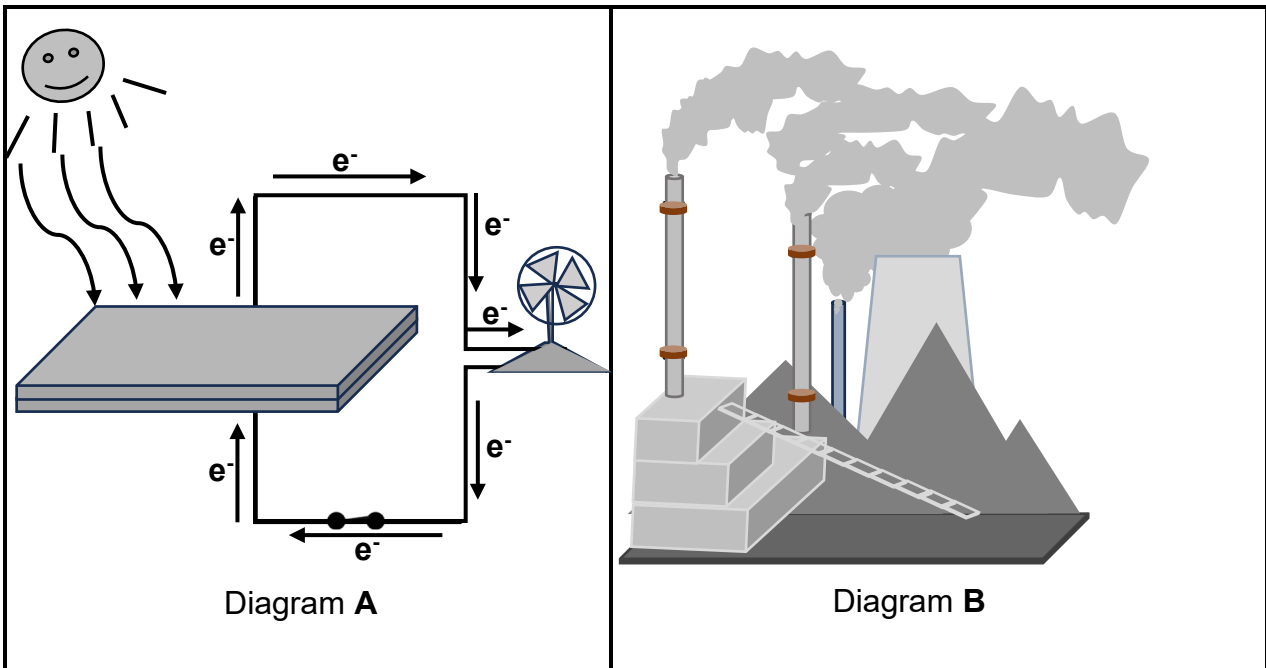

- 7.6 Which ONE of the diagrams above represents energy that has the most negative impact on the environment? Write **DIAGRAM A** or **DIAGRAM B** only. (1)
- 7.7 Give a reason for the answer to QUESTION 7.6. (2)
- 7.8 Briefly explain why South Africa is best suited to utilise the energy source represented in Diagram **A**. (2)
- 7.9 Write down ONE other source of energy, other than the sources represented in Diagrams **A** and **B**. (1)

[17]

**TOTAL: 75**



**DATA FOR TECHNICAL SCIENCES GRADE 12  
PAPER 2  
GEGEWENS VIR TEGNIESE WETENSKAPPE GRAAD 12  
VRAESTEL 2**

**TABLE 1/TABEL 1: PHYSICAL CONSTANTS/FISIESTE KONSTANTES**

<b>NAME/NAAM</b>	<b>SYMBOL/SIMBOOL</b>	<b>VALUE/WAARDE</b>
Standard pressure <i>Standaarddruk</i>	$p^\theta$	$1,01 \times 10^5 \text{ Pa}$
Standard temperature <i>Standaardtemperatuur</i>	$T^\theta$	$0 \text{ }^\circ\text{C}/273 \text{ K}$

**TABLE 2/TABEL 2: FORMULAE/FORMULES**

Emf/ <i>Emk</i>	$E^\theta_{\text{cell}} = E^\theta_{\text{cathode}} - E^\theta_{\text{anode}} \quad / \quad E^\theta_{\text{sel}} = E^\theta_{\text{katode}} - E^\theta_{\text{anode}}$
	<i>or/of</i>
	$E^\theta_{\text{cell}} = E^\theta_{\text{reduction}} - E^\theta_{\text{oxidation}} \quad / \quad E^\theta_{\text{sel}} = E^\theta_{\text{reduksie}} - E^\theta_{\text{oksidasie}}$
	<i>or/of</i>
	$E^\theta_{\text{cell}} = E^\theta_{\text{oxidising agent}} - E^\theta_{\text{reducing agent}} \quad / \quad E^\theta_{\text{sel}} = E^\theta_{\text{oksideermiddel}} - E^\theta_{\text{reduseermiddel}}$





**TABLE 4A: STANDARD REDUCTION POTENTIALS**  
**TABEL 4A: STANDAARD-REDUKSIEPOTENSIALE**

Increasing strength of oxidising agents/Toenemende sterkte van oksideermiddels

Half-reactions/Halfreaksies		E° (V)
$F_2(g) + 2e^-$	$\rightleftharpoons 2F^-$	+ 2,87
$Co^{3+} + e^-$	$\rightleftharpoons Co^{2+}$	+ 1,81
$H_2O_2 + 2H^+ + 2e^-$	$\rightleftharpoons 2H_2O$	+1,77
$MnO_4^- + 8H^+ + 5e^-$	$\rightleftharpoons Mn^{2+} + 4H_2O$	+ 1,51
$Cl_2(g) + 2e^-$	$\rightleftharpoons 2Cl^-$	+ 1,36
$Cr_2O_7^{2-} + 14H^+ + 6e^-$	$\rightleftharpoons 2Cr^{3+} + 7H_2O$	+ 1,33
$O_2(g) + 4H^+ + 4e^-$	$\rightleftharpoons 2H_2O$	+ 1,23
$MnO_2 + 4H^+ + 2e^-$	$\rightleftharpoons Mn^{2+} + 2H_2O$	+ 1,23
$Pt^{2+} + 2e^-$	$\rightleftharpoons Pt$	+ 1,20
$Br_2(l) + 2e^-$	$\rightleftharpoons 2Br^-$	+ 1,07
$NO_3^- + 4H^+ + 3e^-$	$\rightleftharpoons NO(g) + 2H_2O$	+ 0,96
$Hg^{2+} + 2e^-$	$\rightleftharpoons Hg(l)$	+ 0,85
$Ag^+ + e^-$	$\rightleftharpoons Ag$	+ 0,80
$NO_3^- + 2H^+ + e^-$	$\rightleftharpoons NO_2(g) + H_2O$	+ 0,80
$Fe^{3+} + e^-$	$\rightleftharpoons Fe^{2+}$	+ 0,77
$O_2(g) + 2H^+ + 2e^-$	$\rightleftharpoons H_2O_2$	+ 0,68
$I_2 + 2e^-$	$\rightleftharpoons 2I^-$	+ 0,54
$Cu^+ + e^-$	$\rightleftharpoons Cu$	+ 0,52
$SO_2 + 4H^+ + 4e^-$	$\rightleftharpoons S + 2H_2O$	+ 0,45
$2H_2O + O_2 + 4e^-$	$\rightleftharpoons 4OH^-$	+ 0,40
$Cu^{2+} + 2e^-$	$\rightleftharpoons Cu$	+ 0,34
$SO_4^{2-} + 4H^+ + 2e^-$	$\rightleftharpoons SO_2(g) + 2H_2O$	+ 0,17
$Cu^{2+} + e^-$	$\rightleftharpoons Cu^+$	+ 0,16
$Sn^{4+} + 2e^-$	$\rightleftharpoons Sn^{2+}$	+ 0,15
$S + 2H^+ + 2e^-$	$\rightleftharpoons H_2S(g)$	+ 0,14
<b><math>2H^+ + 2e^-</math></b>	<b><math>\rightleftharpoons H_2(g)</math></b>	<b>0,00</b>
$Fe^{3+} + 3e^-$	$\rightleftharpoons Fe$	- 0,06
$Pb^{2+} + 2e^-$	$\rightleftharpoons Pb$	- 0,13
$Sn^{2+} + 2e^-$	$\rightleftharpoons Sn$	- 0,14
$Ni^{2+} + 2e^-$	$\rightleftharpoons Ni$	- 0,27
$Co^{2+} + 2e^-$	$\rightleftharpoons Co$	- 0,28
$Cd^{2+} + 2e^-$	$\rightleftharpoons Cd$	- 0,40
$Cr^{3+} + e^-$	$\rightleftharpoons Cr^{2+}$	- 0,41
$Fe^{2+} + 2e^-$	$\rightleftharpoons Fe$	- 0,44
$Cr^{3+} + 3e^-$	$\rightleftharpoons Cr$	- 0,74
$Zn^{2+} + 2e^-$	$\rightleftharpoons Zn$	- 0,76
$2H_2O + 2e^-$	$\rightleftharpoons H_2(g) + 2OH^-$	- 0,83
$Cr^{2+} + 2e^-$	$\rightleftharpoons Cr$	- 0,91
$Mn^{2+} + 2e^-$	$\rightleftharpoons Mn$	- 1,18
$Al^{3+} + 3e^-$	$\rightleftharpoons Al$	- 1,66
$Mg^{2+} + 2e^-$	$\rightleftharpoons Mg$	- 2,36
$Na^+ + e^-$	$\rightleftharpoons Na$	- 2,71
$Ca^{2+} + 2e^-$	$\rightleftharpoons Ca$	- 2,87
$Sr^{2+} + 2e^-$	$\rightleftharpoons Sr$	- 2,89
$Ba^{2+} + 2e^-$	$\rightleftharpoons Ba$	- 2,90
$Cs^+ + e^-$	$\rightleftharpoons Cs$	- 2,92
$K^+ + e^-$	$\rightleftharpoons K$	- 2,93
$Li^+ + e^-$	$\rightleftharpoons Li$	- 3,05

Increasing strength of reducing agents/Toenemende sterkte van reduseermiddels



**TABLE 4B: STANDARD REDUCTION POTENTIALS**  
**TABEL 4B: STANDAARD-REDUKSIEPOTENSIALE**

Half-reactions/Halfreaksies		E <sup>0</sup> (V)
Li <sup>+</sup> + e <sup>-</sup>	⇌ Li	- 3,05
K <sup>+</sup> + e <sup>-</sup>	⇌ K	- 2,93
Cs <sup>+</sup> + e <sup>-</sup>	⇌ Cs	- 2,92
Ba <sup>2+</sup> + 2e <sup>-</sup>	⇌ Ba	- 2,90
Sr <sup>2+</sup> + 2e <sup>-</sup>	⇌ Sr	- 2,89
Ca <sup>2+</sup> + 2e <sup>-</sup>	⇌ Ca	- 2,87
Na <sup>+</sup> + e <sup>-</sup>	⇌ Na	- 2,71
Mg <sup>2+</sup> + 2e <sup>-</sup>	⇌ Mg	- 2,36
Al <sup>3+</sup> + 3e <sup>-</sup>	⇌ Al	- 1,66
Mn <sup>2+</sup> + 2e <sup>-</sup>	⇌ Mn	- 1,18
Cr <sup>2+</sup> + 2e <sup>-</sup>	⇌ Cr	- 0,91
2H <sub>2</sub> O + 2e <sup>-</sup>	⇌ H <sub>2</sub> (g) + 2OH <sup>-</sup>	- 0,83
Zn <sup>2+</sup> + 2e <sup>-</sup>	⇌ Zn	- 0,76
Cr <sup>3+</sup> + 3e <sup>-</sup>	⇌ Cr	- 0,74
Fe <sup>2+</sup> + 2e <sup>-</sup>	⇌ Fe	- 0,44
Cr <sup>3+</sup> + e <sup>-</sup>	⇌ Cr <sup>2+</sup>	- 0,41
Cd <sup>2+</sup> + 2e <sup>-</sup>	⇌ Cd	- 0,40
Co <sup>2+</sup> + 2e <sup>-</sup>	⇌ Co	- 0,28
Ni <sup>2+</sup> + 2e <sup>-</sup>	⇌ Ni	- 0,27
Sn <sup>2+</sup> + 2e <sup>-</sup>	⇌ Sn	- 0,14
Pb <sup>2+</sup> + 2e <sup>-</sup>	⇌ Pb	- 0,13
Fe <sup>3+</sup> + 3e <sup>-</sup>	⇌ Fe	- 0,06
<b>2H<sup>+</sup> + 2e<sup>-</sup></b>	<b>⇌ H<sub>2</sub>(g)</b>	<b>0,00</b>
S + 2H <sup>+</sup> + 2e <sup>-</sup>	⇌ H <sub>2</sub> S(g)	+ 0,14
Sn <sup>4+</sup> + 2e <sup>-</sup>	⇌ Sn <sup>2+</sup>	+ 0,15
Cu <sup>2+</sup> + e <sup>-</sup>	⇌ Cu <sup>+</sup>	+ 0,16
SO <sub>4</sub> <sup>2-</sup> + 4H <sup>+</sup> + 2e <sup>-</sup>	⇌ SO <sub>2</sub> (g) + 2H <sub>2</sub> O	+ 0,17
Cu <sup>2+</sup> + 2e <sup>-</sup>	⇌ Cu	+ 0,34
2H <sub>2</sub> O + O <sub>2</sub> + 4e <sup>-</sup>	⇌ 4OH <sup>-</sup>	+ 0,40
SO <sub>2</sub> + 4H <sup>+</sup> + 4e <sup>-</sup>	⇌ S + 2H <sub>2</sub> O	+ 0,45
Cu <sup>+</sup> + e <sup>-</sup>	⇌ Cu	+ 0,52
I <sub>2</sub> + 2e <sup>-</sup>	⇌ 2I <sup>-</sup>	+ 0,54
O <sub>2</sub> (g) + 2H <sup>+</sup> + 2e <sup>-</sup>	⇌ H <sub>2</sub> O <sub>2</sub>	+ 0,68
Fe <sup>3+</sup> + e <sup>-</sup>	⇌ Fe <sup>2+</sup>	+ 0,77
NO <sub>3</sub> <sup>-</sup> + 2H <sup>+</sup> + e <sup>-</sup>	⇌ NO <sub>2</sub> (g) + H <sub>2</sub> O	+ 0,80
Ag <sup>+</sup> + e <sup>-</sup>	⇌ Ag	+ 0,80
Hg <sup>2+</sup> + 2e <sup>-</sup>	⇌ Hg(l)	+ 0,85
NO <sub>3</sub> <sup>-</sup> + 4H <sup>+</sup> + 3e <sup>-</sup>	⇌ NO(g) + 2H <sub>2</sub> O	+ 0,96
Br <sub>2</sub> (l) + 2e <sup>-</sup>	⇌ 2Br <sup>-</sup>	+ 1,07
Pt <sup>2+</sup> + 2e <sup>-</sup>	⇌ Pt	+ 1,20
MnO <sub>2</sub> + 4H <sup>+</sup> + 2e <sup>-</sup>	⇌ Mn <sup>2+</sup> + 2H <sub>2</sub> O	+ 1,23
O <sub>2</sub> (g) + 4H <sup>+</sup> + 4e <sup>-</sup>	⇌ 2H <sub>2</sub> O	+ 1,23
Cr <sub>2</sub> O <sub>7</sub> <sup>2-</sup> + 14H <sup>+</sup> + 6e <sup>-</sup>	⇌ 2Cr <sup>3+</sup> + 7H <sub>2</sub> O	+ 1,33
Cl <sub>2</sub> (g) + 2e <sup>-</sup>	⇌ 2Cl <sup>-</sup>	+ 1,36
MnO <sub>4</sub> <sup>-</sup> + 8H <sup>+</sup> + 5e <sup>-</sup>	⇌ Mn <sup>2+</sup> + 4H <sub>2</sub> O	+ 1,51
H <sub>2</sub> O <sub>2</sub> + 2H <sup>+</sup> + 2e <sup>-</sup>	⇌ 2H <sub>2</sub> O	+ 1,77
Co <sup>3+</sup> + e <sup>-</sup>	⇌ Co <sup>2+</sup>	+ 1,81
F <sub>2</sub> (g) + 2e <sup>-</sup>	⇌ 2F <sup>-</sup>	+ 2,87

Increasing strength of oxidising agents/Toenemende sterkte van oksideermiddels

Increasing strength of reducing agents/Toenemende sterkte van reduseermiddels

