

Confidential



# basic education

Department:  
Basic Education  
**REPUBLIC OF SOUTH AFRICA**

## **SENIOR CERTIFICATE EXAMINATIONS/ NATIONAL SENIOR CERTIFICATE EXAMINATIONS**

**TECHNICAL SCIENCES P1**

**MAY/JUNE 2025**

**MARKS: 150**

**TIME: 3 hours**

**This question paper consists of 17 pages and 2 data sheets.**



**INSTRUCTIONS AND INFORMATION**

1. Write your centre number and examination number in the appropriate spaces on the ANSWER BOOK.
2. This question paper consists of TEN questions. Answer ALL the questions in the ANSWER BOOK.
3. Start EACH question on a NEW page in the ANSWER BOOK.
4. Number the answers correctly according to the numbering system used in this question paper.
5. Leave ONE line between two subquestions, e.g. between QUESTION 2.1 and QUESTION 2.2.
6. You may use a non-programmable calculator.
7. You may use appropriate mathematical instruments.
8. You are advised to use the attached DATA SHEETS.
9. Show ALL formulae and substitutions in ALL calculations.
10. Round off your FINAL numerical answers to a minimum of TWO decimal places.
11. Give brief motivations, discussions, etc. where required.
12. Write neatly and legibly....



**QUESTION 1: MULTIPLE-CHOICE QUESTIONS**

Various options are provided as possible answers to the following questions. Choose the answer and write only the letter (A–D) next to the question numbers (1.1 to 1.10) in the ANSWER BOOK, e.g. 1.11 D.

1.1 When an object moves at constant velocity, the resultant force acting on it is zero. This is TRUE because its ...

A mass is less than zero.

B mass is greater than zero.

C acceleration is equal to zero.

D acceleration is less than zero.

(2)

1.2 The force diagram below shows the forces acting on a box.

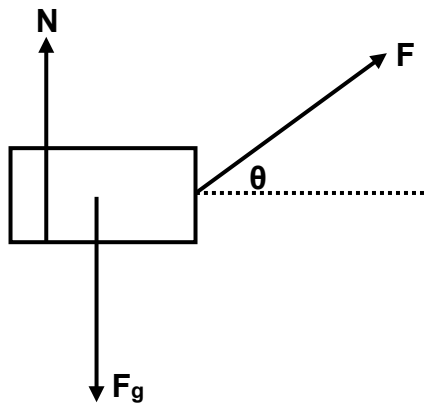

The CORRECT equation for the normal force is ...

A  $N = F_g + F \cos \theta$

B  $N = F_g + F \sin \theta$

C  $N = F_g - F \cos \theta$

D  $N = F_g - F \sin \theta$

(2)



- 1.3 The graph below shows the relationship between the change in momentum ( $\Delta p$ ) and change in time ( $\Delta t$ ).

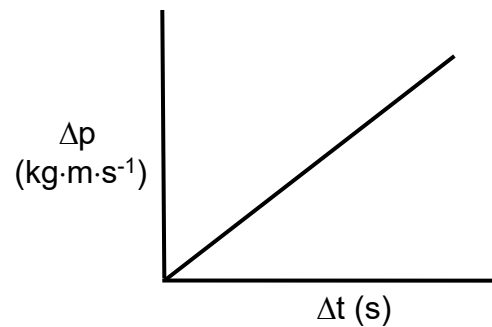

Which ONE of the following physical quantities is represented by the gradient of this graph?

- A Resultant force
- B Impulse
- C Energy
- D Work (2)
- 1.4 Power is defined as the ...
- A rate at which velocity changes.
- B rate at which work is done.
- C product of the mass of an object and its velocity.
- D product of the mass of an object and its acceleration. (2)
- 1.5 The working of hydraulic jacks is an application of ...
- A Lenz's law.
- B Hooke's law.
- C Pascal's law.
- D Faraday's law. (2)



- 1.6 Consider the diagram of a hydraulic press below and answer the question that follows.



The area on which  $F_A$  acts is smaller than that on which  $F_B$  acts.

Which ONE of the following is TRUE regarding the magnitudes of these forces?

- A  $F_A > F_B$
- B  $F_A < F_B$
- C  $F_A = F_B$
- D  $F_A \geq F_B$  (2)

- 1.7 The critical angle of water with respect to air is  $48,6^\circ$ .

At which angle of incidence will total internal reflection take place if a light ray from a source under water strikes the water-air interface?

- A  $90^\circ$
- B  $48,6^\circ$
- C  $30^\circ$
- D  $60^\circ$  (2)



1.8 Which ONE of the graphs below BEST describes the relationship between the amount of charge stored in the capacitor and the time taken during the charging process?

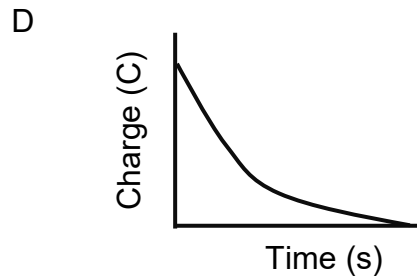
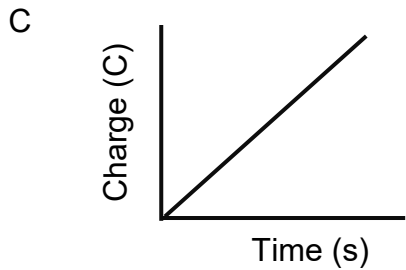
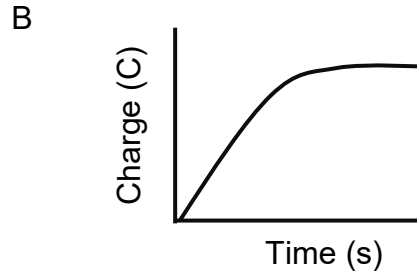
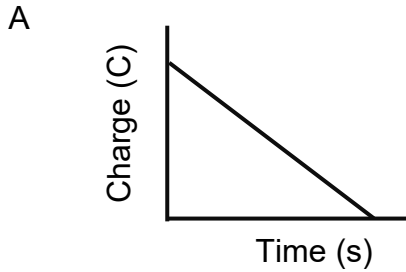

(2)

1.9 To calculate the cost of electricity, the practical unit of power must be given in ...

- A kWh
- B kW
- C MW
- D W

(2)

1.10 The direction of the induced emf in a coil opposes the effect that produces it.

This is best explained by ...

- A the right-hand dynamo rule.
- B the left-hand motor rule.
- C Faraday's law.
- D Lenz's law.

(2)  
[20]



**QUESTION 2 (Start on a new page.)**

Two blocks of masses 4 kg and 2 kg respectively are connected by a light inextensible string, as shown below.

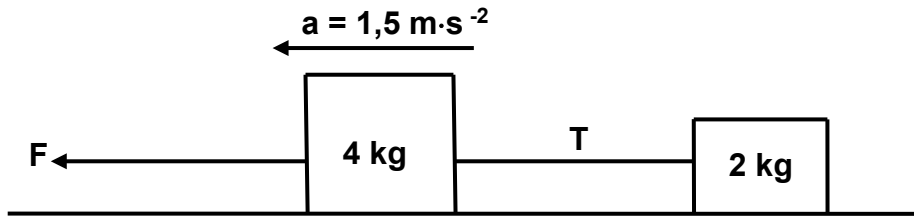

When force **F** is applied to the 4 kg block, both blocks accelerate to the left at  $1,5 \text{ m}\cdot\text{s}^{-2}$ . The frictional forces between the floor and the 4 kg and 2 kg blocks are 4,5 N and 3,5 N respectively. The tension in the string is **T**.

- 2.1 State *Newton's second law of motion* in words. (2)
- 2.2 Draw a labelled free-body diagram to show ALL the forces acting on the 4 kg block. (5)
- 2.3 Calculate the magnitude of:
  - 2.3.1 The tension, **T**, in the string (3)
  - 2.3.2 The force **F** (4)
- 2.4 A boy is standing at the back of a truck which is travelling at  $30 \text{ km}\cdot\text{h}^{-1}$  to the right, as shown in the diagram below.

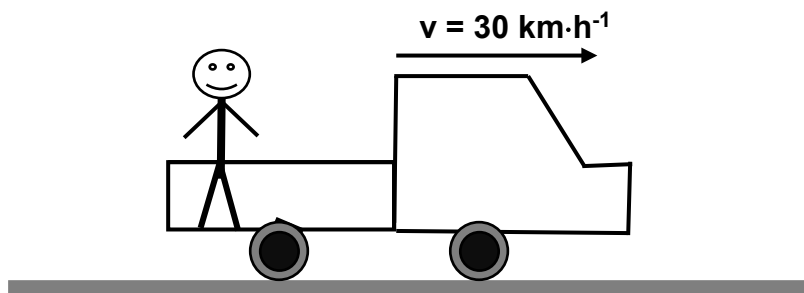

- 2.4.1 Convert  $30 \text{ km}\cdot\text{h}^{-1}$  to  $\text{m}\cdot\text{s}^{-1}$ . (2)
  - 2.4.2 What will happen to the boy if the truck suddenly stops? (2)
  - 2.4.3 Name and define the property of matter applied in QUESTION 2.4.2. (3)
- [21]**



**QUESTION 3 (Start on a new page.)**

Truck X, of mass 1 500 kg, is moving eastwards with a velocity of  $30 \text{ m}\cdot\text{s}^{-1}$  and collides with a stationary truck Y, of mass 800 kg. Truck Y is loaded with sound equipment of mass 200 kg. After the collision, the two trucks move together. Ignore the effects of friction.

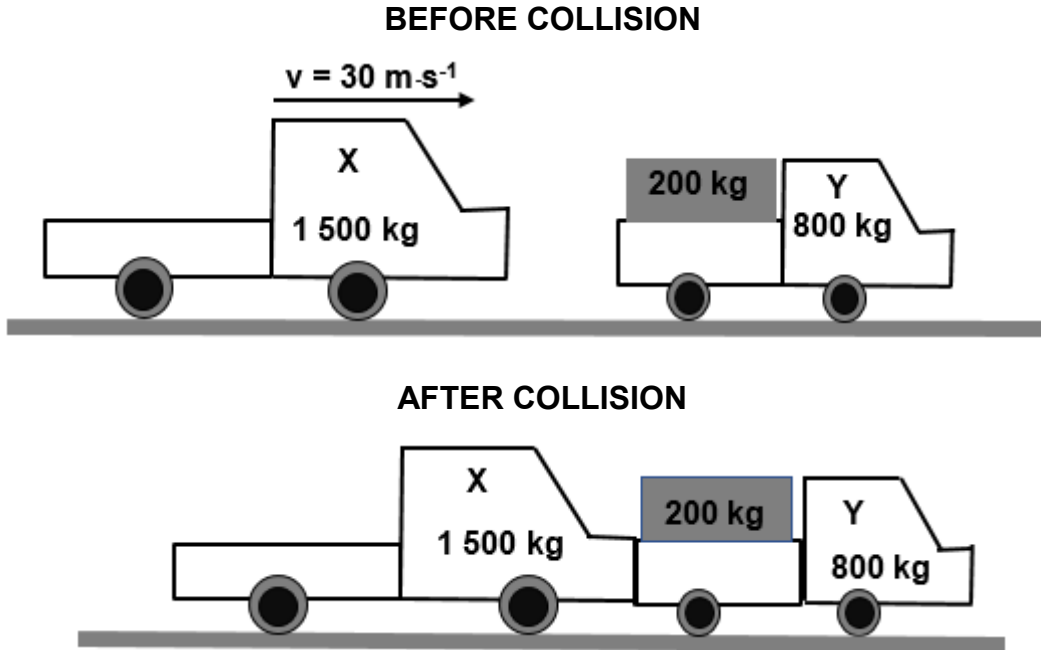

- 3.1 State the *principle of conservation of linear momentum* in words. (2)
  - 3.2 Calculate the:
    - 3.2.1 Velocity of the trucks after the collision (5)
    - 3.2.2 Magnitude of the force that truck X exerts on truck Y if the collision lasts for 0,2 s (4)
  - 3.3 The sound equipment on the stationary truck is wrapped with bubble plastic instead of ordinary plastic. Using physics principles, explain why this is advisable. (3)
- [14]**



**QUESTION 4 (Start on a new page.)**

The diagram below shows water falling from rest at point **A** to point **B** towards a turbine that is placed in its path. The water moves the turbine, which in turn powers a generator. Points **A** and **B** are 192 m apart and **B** is 10 m above the ground. The mass of the falling water is  $5,5 \times 10^{11}$  kg.

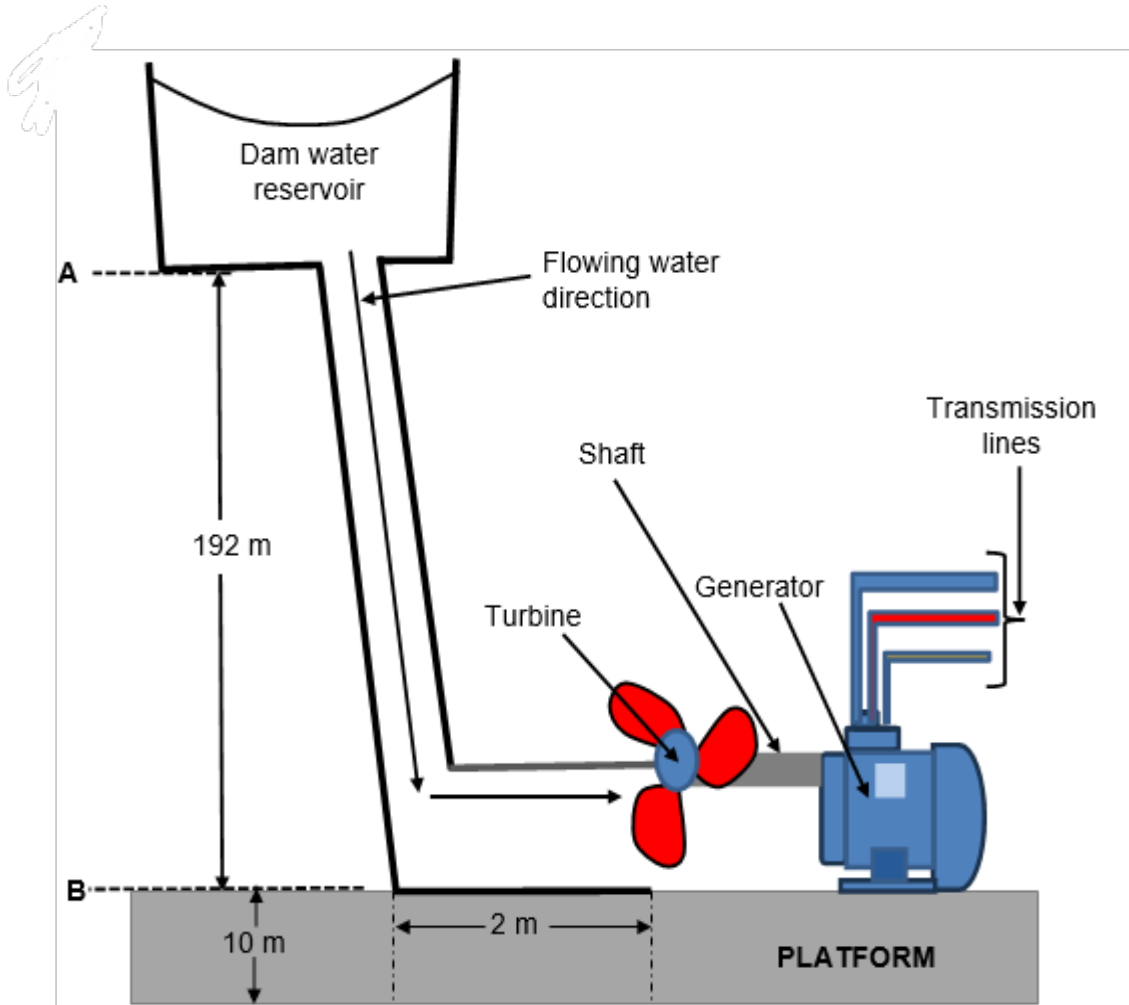

- 4.1 Define the term *mechanical energy* in words. (2)
- 4.2 Calculate the:
  - 4.2.1 Mechanical energy of the water at point **A** (4)
  - 4.2.2 Velocity of the water at point **B** (5)



- 4.3 A frictional force of  $5,39 \times 10^{12}$  N acts on the water as it falls from point **A** to **B**. It falls at a CONSTANT VELOCITY over a period of 2 minutes to complete the drop.

Calculate the average power of the falling water. (4)

- 4.4 After hitting the lowest point **B**, the water continues to flow over a horizontal distance of 2 m towards a turbine that is placed in its path. During this period, the water experiences a frictional force of  $4,27 \times 10^2$  N.

4.4.1 Draw a free-body diagram showing ALL the forces acting on the water as it flows over the 2 m distance towards the turbine. (3)

4.4.2 Calculate the work done by the frictional force on the water as it moves along the distance of 2 m towards the turbine. (4)  
**[22]**



**QUESTION 5 (Start on a new page.)**

- 5.1 Define the term *perfectly plastic body*. (2)
- 5.2 Give THREE examples of perfectly plastic bodies. (3)
- 5.3 A metal wire has a diameter of 4 mm and a length of 2,5 m. A force of 10 N is applied.  
Calculate the stress in the metal wire. (5)
- 5.4 Define the term *hydraulics*. (2)
- 5.5 Write down TWO conditions that a liquid must satisfy for Pascal's law to be applicable. (2)
- 5.6 A diagram of a hydraulic gripper, a heavy-duty lifting machine that is required to handle heavy components, is shown below. A pressurised liquid is used to develop a force that moves a piston.

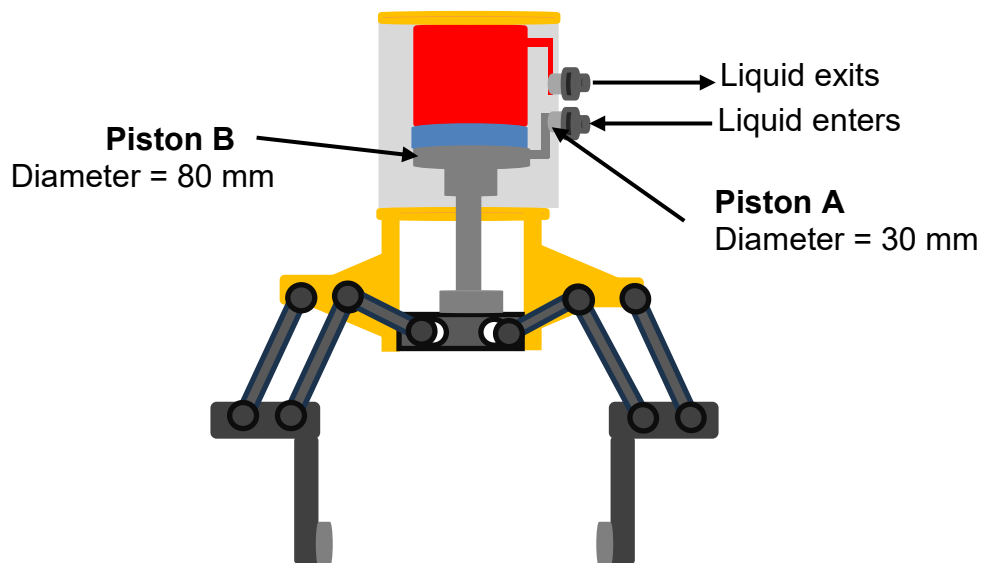

The diameter of piston **A** is 30 mm and that of piston **B** is 80 mm. The hydraulic gripper above lifts a load of 5 100 N.

Calculate the force experienced by the liquid in piston **A**. (4)



- 5.7 Study the diagram of a multigrade motor engine oil bottle below and then answer the questions that follow.

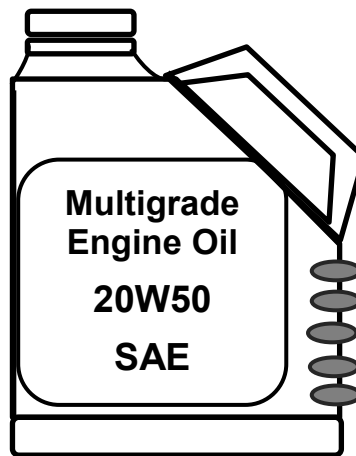

- 5.7.1 Define the term *viscosity*. (2)
- 5.7.2 Explain what 20W50 indicates. (2)
- 5.7.3 Write down ONE way in which the viscosity of motor oil can be increased. (2)
- [24]**



**QUESTION 6 (Start on a new page.)**

A telescope uses a type of lens that make distant objects appear nearer. Study the diagram of a telescope below and then answer the questions that follow.

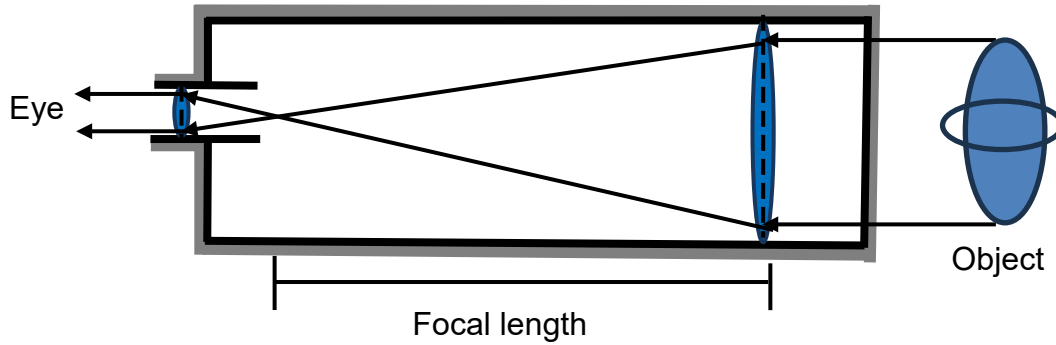

- 6.1 Define the term *focal length*. (2)
- 6.2 Identify the type of lenses used in this telescope. (1)
- 6.3 Explain the answer to QUESTION 6.2 above. (1)
- 6.4 Write down the eye condition that is corrected by this type of lens. (1)
- 6.5 A light ray is directed towards a rectangular glass block from the air, at an angle of  $28^\circ$  between the light ray and the normal, as shown in the diagram below. The light ray enters and exits the glass block.

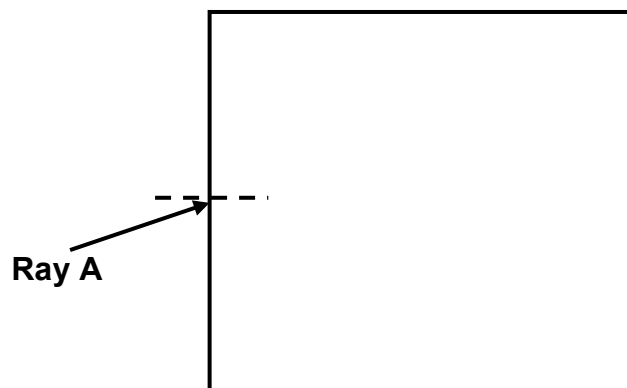

- 6.5.1 Define the term *refraction*. (2)
- 6.5.2 Redraw the diagram and show the complete path of the light ray from the time it enters the glass block until it exits.

In the diagram, label the following:

- ALL light rays
- ALL angles
- The magnitudes of at least TWO angles

(7)  
[14]



**QUESTION 7 (Start on a new page.)**

Electromagnetic waves are used extensively in our daily lives. Wi-Fi is a popular tool used for electronic communication.

- 7.1 What type of waves are electromagnetic waves? Choose from TRANSVERSE or LONGITUDINAL waves. (1)
- 7.2 Name the type of electromagnetic wave used in Wi-Fi. (1)
- 7.3 Why is this type of electromagnetic wave in QUESTION 7.2 suitable for use in Wi-Fi? (2)
- 7.4 Calculate the frequency of ultraviolet light with a wavelength of 400 nm. Give the final answer in kHz. (4)
- [8]**



**QUESTION 8 (Start on a new page.)**

A capacitor that has a capacitance of  $100 \mu\text{F}$  is connected in an electric circuit, as shown below. The area of the plate is  $500 \text{ cm}^2$  and the capacitor is charged to FULL capacitance. The dielectric is air.

When the circuit is in operation, the LED shines a red light.

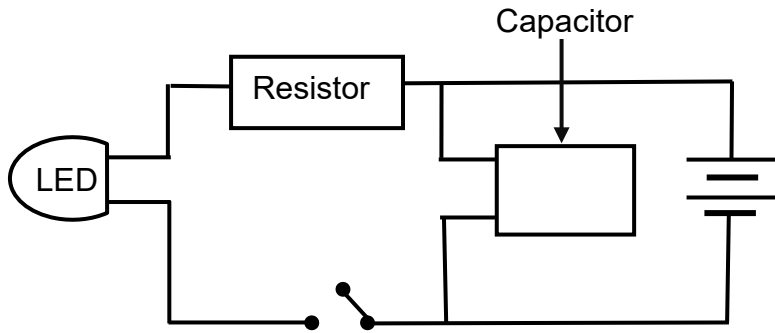

- 8.1 What is the function of the dielectric between the metal plates of a capacitor? (1)
- 8.2 Calculate the distance between the metal plates of this capacitor. (4)
- 8.3 The battery is now disconnected from the electric circuit and the switch is closed.

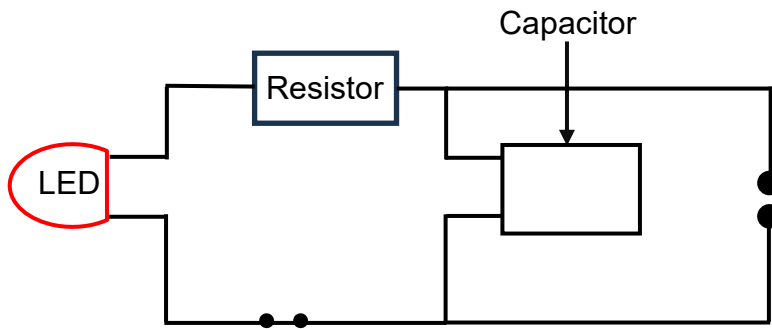

- 8.3.1 What will be observed at the LED? (1)
- 8.3.2 Explain the answer to QUESTION 8.3.1 above. (2)
- 8.4 Write down ONE application of capacitors in technology. (1)

**[9]**



**QUESTION 9 (Start on a new page.)**

Study the circuit diagram below and answer the questions that follow. Ignore the resistances of the battery and the conducting wires.

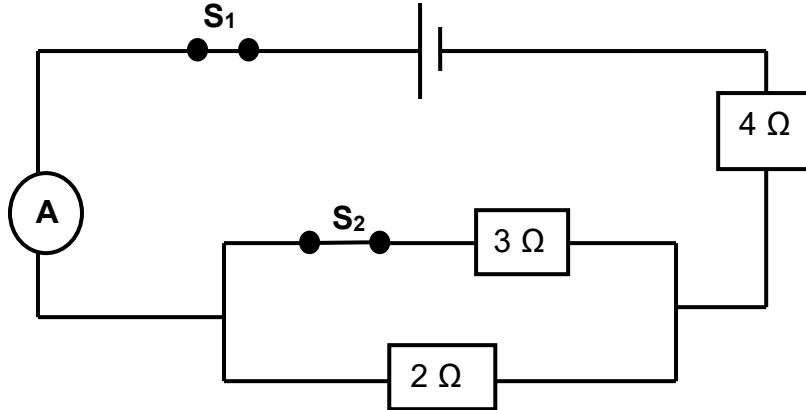

- 9.1 How should a voltmeter be connected to measure the potential difference across the ends of the battery? (1)
  - 9.2 With both switches S<sub>1</sub> and S<sub>2</sub> closed, calculate the total resistance in the circuit. (4)
  - 9.3 Switch S<sub>2</sub> is now open. How will the current in ammeter A be affected? Choose from INCREASES, DECREASES or REMAINS THE SAME. (1)
  - 9.4 Explain the answer to QUESTION 9.3. (2)
- [8]**



**QUESTION 10 (Start on a new page.)**

The simplified sketch below represents a generator.

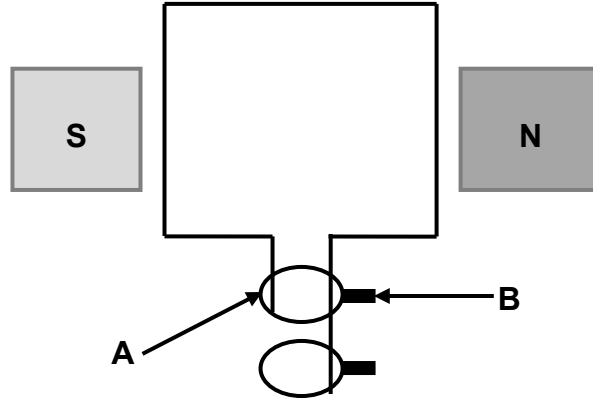

- 10.1 What type of a generator is shown in the sketch above? Write DC or AC. (1)
- 10.2 Write down the names of the components labelled:
  - 10.2.1 **A** (1)
  - 10.2.2 **B** (1)
- 10.3 Name ONE change that can be made to the generator above to improve its output. (1)
- 10.4 A bar magnet has a flux density of 4 T and a cross-sectional area of 2 cm<sup>2</sup>.
  - 10.4.1 Define the term *magnetic flux*. (2)
  - 10.4.2 Calculate the magnetic flux at the poles. (4)

**[10]**

**TOTAL: 150**





**DATA FOR TECHNICAL SCIENCES GRADE 12  
PAPER 1**

**GEGEWENS VIR TEGNIESE WETENSKAPPE GRAAD 12  
VRAESTEL 1**

**TABLE 1: PHYSICAL CONSTANTS/TABEL 1: FISIESE KONSTANTES**

NAME/NAAM	SYMBOL/SIMBOOL	VALUE/WAARDE
Acceleration due to gravity <i>Swaartekragversnelling</i>	g	9,8 m·s <sup>-2</sup>
Speed of light in a vacuum <i>Spoed van lig in 'n vakuum</i>	c	3,0 x 10 <sup>8</sup> m·s <sup>-1</sup>
Planck's constant <i>Planck se konstante</i>	h	6,63 x 10 <sup>-34</sup> J·s
Electron mass <i>Elektronmassa</i>	m <sub>e</sub>	9,11 x 10 <sup>-31</sup> kg
Permittivity of free space <i>Permittiwiteit van vrye ruimte</i>	ε <sub>0</sub>	8,85 x 10 <sup>-12</sup> F·m <sup>-1</sup>

**TABLE 2: FORMULAE/TABEL 2: FORMULES**

**FORCE/KRAG**

$F_{\text{net}} = ma$	$p = mv$
$f_s^{\text{max}} = \mu_s N$	$f_k = \mu_k N$
$F_{\text{net}} \Delta t = \Delta p$ $\Delta p = mv_i - mv_f$	$F_g = mg$
$v = \frac{\Delta x}{\Delta t}$	$a = \frac{\Delta v}{\Delta t}$

**WORK, ENERGY AND POWER/ARBEID, ENERGIE EN DRYWING**

$W = F\Delta x \cos \theta$	$U = mgh$ or/of $E_p = mgh$
$K = \frac{1}{2} mv^2$ or/of $E_k = \frac{1}{2} mv^2$	$M_E = E_k + E_p$
$P_{\text{ave}} = Fv_{\text{ave}}$ / $P_{\text{gemid}} = Fv_{\text{gemid}}$	$P = \frac{W}{\Delta t}$



**ELASTICITY, VISCOSITY AND HYDRAULICS/ELASTISITEIT, VISKOSITEIT EN HIDROULIKA**

$\sigma = \frac{F}{A}$	$\epsilon = \frac{\Delta l}{L}$
$\frac{\sigma}{\epsilon} = K$	$\frac{F_1}{A_1} = \frac{F_2}{A_2}$
$P = \frac{F}{A}$	$P = \rho gh$

**ELECTROSTATICS/ELEKTROSTATIKA**

$C = \frac{Q}{V}$	$C = \frac{\epsilon_0 A}{d}$
-------------------	------------------------------

**CURRENT ELECTRICITY/STROOMELEKTRISITEIT**

$R = \frac{V}{I}$	$R_s = R_1 + R_2 + \dots$ $\frac{1}{R_p} = \frac{1}{R_1} + \frac{1}{R_2} + \dots$
$W = VQ$ $W = VI\Delta t$ $W = I^2R \Delta t$ $W = \frac{V^2\Delta t}{R}$	$P = \frac{W}{\Delta t}$ $P = VI$ $P = I^2R$ $P = \frac{V^2}{R}$

**ELECTROMAGNETISM/ELEKTROMAGNETISME**

$\Phi = BA$	$\epsilon = -N \frac{\Delta\Phi}{\Delta t}$
$\frac{V_s}{V_p} = \frac{N_s}{N_p}$	

**WAVES, SOUND AND LIGHT/GOLWE, KLANK EN LIG**

$v = f\lambda$	$T = \frac{1}{f}$
$E = hf$ or/of $E = h\frac{c}{\lambda}$	

