



# basic education

Department:  
Basic Education  
**REPUBLIC OF SOUTH AFRICA**

## **SENIOR CERTIFICATE EXAMINATIONS/ NATIONAL SENIOR CERTIFICATE EXAMINATIONS**

**TECHNICAL SCIENCES P1**

**2022**

**MARKS: 150**

**TIME: 3 hours**



**This question paper consists of 16 pages, 3 data sheets and  
a sheet of graph paper.**

**INSTRUCTIONS AND INFORMATION**

1. Write your centre number and examination number in the appropriate spaces on the ANSWER BOOK.
2. This question paper consists of TEN questions. Answer ALL the questions in the ANSWER BOOK.
3. Start EACH question on a NEW page in the ANSWER BOOK.
4. Number the answers correctly according to the numbering system used in this question paper.
5. Leave ONE line between two subquestions, e.g. between QUESTION 2.1 and QUESTION 2.2.
6. You may use a non-programmable calculator.
7. You may use appropriate mathematical instruments.
8. You are advised to use the attached DATA SHEETS.
9. Show ALL formulae and substitutions in ALL calculations.
10. Round off your FINAL numerical answers to a minimum of TWO decimal places.
11. Give brief motivations, discussions etc. where required.
12. Write neatly and legibly.



**QUESTION 1: MULTIPLE-CHOICE QUESTIONS**

Various options are provided as possible answers to the following questions. Choose the answer and write only the letter (A–D) next to the question numbers (1.1 to 1.10) in the ANSWER BOOK, e.g. 1.11 D.

- 1.1 If an object of mass **m** is at rest, the following statement is TRUE:
- A The net force on the object is zero.
  - B The only force acting on the object is the normal.
  - C The applied force is greater than the frictional force.
  - D The only force acting on the object is the weight. (2)
- 1.2 Two moving objects are involved in an inelastic one-dimensional collision. If the total final momentum after the collision is zero, which ONE of the following conditions is necessary?
- A The objects must have the same mass.
  - B The objects must have the same initial velocity.
  - C The objects must have final momenta with the same magnitude but opposite directions.
  - D The objects must have the same initial speed, with velocity in opposite directions. (2)
- 1.3 Suppose an engine uses 1 J of energy to lift the weight, **mg**, in Diagram 1 to a height **h**, and in Diagram 2 the engine lifts a weight **2 mg** to a height **2 h**.

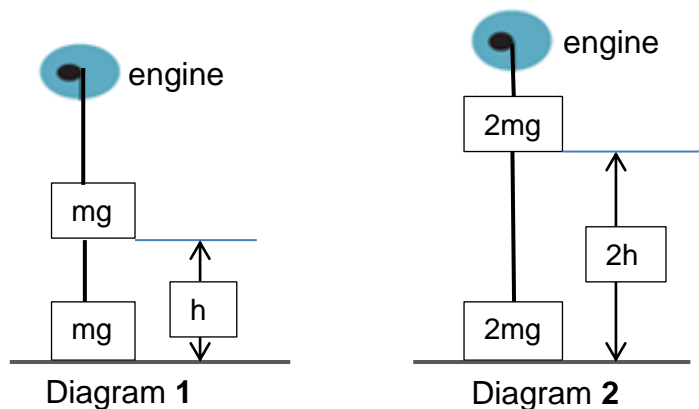

The amount of energy that is needed in Diagram 2 is:

- A 2 J
- B 1 J
- C 0,5 J
- D 4 J (2)



1.4 Which ONE of the following statements defines strain in a material?

Strain is the ratio between the ...

- A change in length and the original length.
- B change in diameter and the original length.
- C total length and the original length.
- D change in stress and the original stress. (2)

1.5 Viscosity is the resistance to ...

- A flow.
- B boiling.
- C cooling.
- D melting. (2)

1.6 In the diagram below a spring is attached to a ceiling. It stretches as a mass piece is attached to the other end of the spring, as shown.

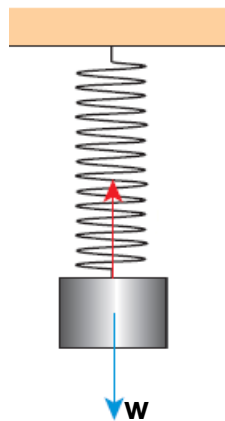

The force,  $w$ , is acting as a ... force.

- A restoring
- B bending
- C shear
- D deforming (2)



- 1.7 The pencil in the glass of water looks bent, although it is not. Which property of light is responsible for this observation?

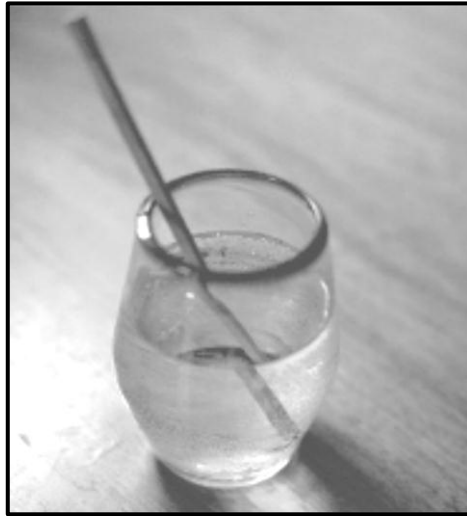

- A Reflection
- B Refraction
- C Diffraction
- D Dispersion (2)
- 1.8 When a compass is placed near a current-carrying conductor, the needle deflects.
- This indicates that ...
- A a magnetic field occurs around the conductor.
- B an electric field occurs around the conductor.
- C the compass has a north and south pole.
- D the current flows from positive to negative. (2)
- 1.9 In a series circuit, which ONE of the following quantities remains the same?
- A Voltage (Potential difference)
- B Capacitance
- C Current
- D Resistance (2)



1.10 Identify the type of device shown in the diagram below:

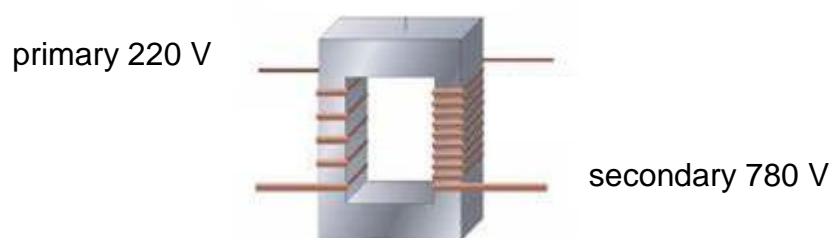

- A Step-up transformer
- B Step-up generator
- C Step-down generator
- D Step-down transformer

(2)  
[20]



**QUESTION 2 (Start on a new page.)**

- 2.1 A car with a weight of 10 000 N is travelling eastwards on a level road, while the engine is applying a force, **F**, eastwards. The car experiences air resistance of 2 500 N. The force of friction exerted by the road on the tyres is 500 N.

Draw a free-body diagram for this situation. (5)

- 2.2 A properly adjusted headrest can minimise or prevent whiplash, an injury on the neck and spine, resulting from the rapid forward acceleration in a rear-end collision.



Name and define the property of a body that causes whiplash. (3)

- 2.3 A team of two athletes, **A** and **B**, are practising to compete in a canoe race. Athlete **A** has a mass of 60 kg, athlete **B** a mass of 65 kg and the canoe a mass of 20 kg. Athlete **A** exerts an average force of 50 N and athlete **B** an average force of 55 N on the canoe using the paddles. During paddling, the magnitude of the water resistance on the canoe is 18 N.

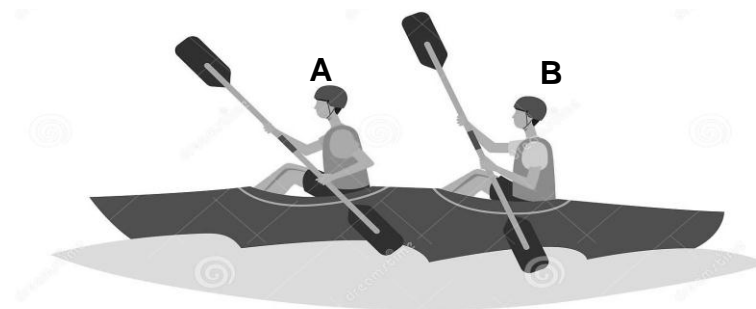

2.3.1 State Newton's Second Law in words. (2)

2.3.2 Calculate the acceleration of the canoe. (4)

2.3.3 When the canoe reaches a velocity of  $3 \text{ m}\cdot\text{s}^{-1}$ , athlete **B** jumps off the canoe to the side.

Calculate the resultant force that is needed to increase the velocity of the canoe to  $5 \text{ m}\cdot\text{s}^{-1}$  in 6 seconds. (4)



- 2.4 A car engine of weight 8 500 N is suspended from a chain block. A horizontal force of 4 750 N is used to pull the engine to the left. The chain that attaches the engine to the crossbar makes an angle of  $29,2^\circ$  with the vertical.

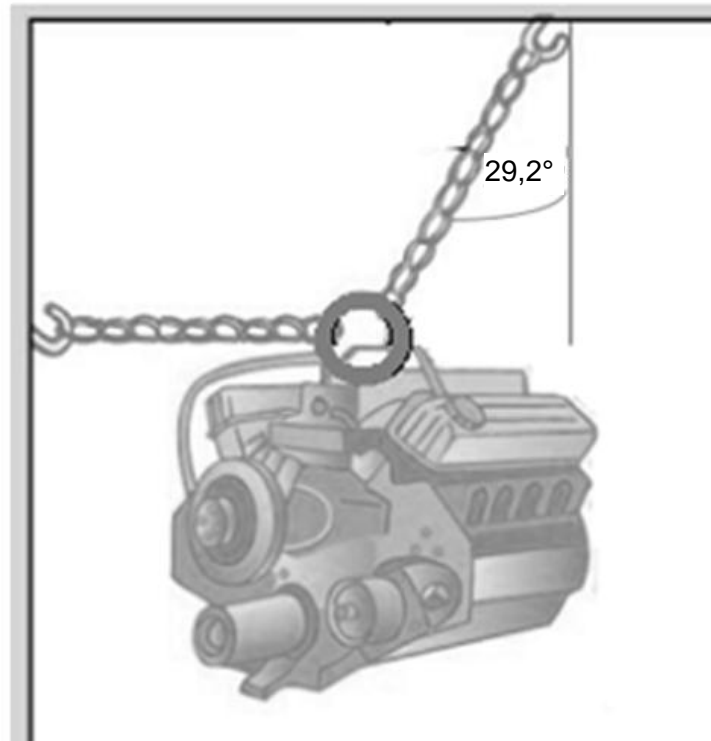

The forces acting on the engine are represented by the following free body diagram:

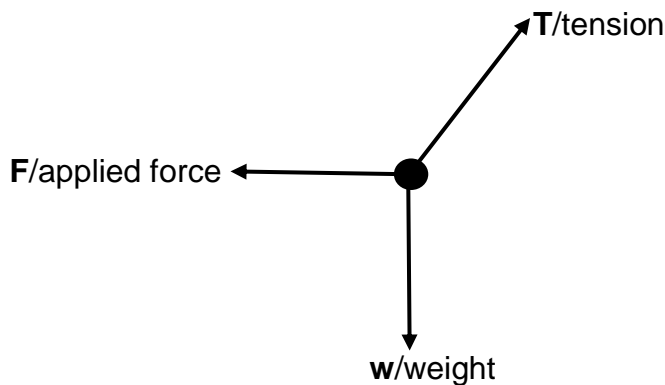

- 2.4.1 State Newton's First Law of Motion in words. (2)
- 2.4.2 Use the head-to-tail method and make a scaled drawing to determine the tension,  $T$ , in the chain. (5)
- Use scale: 1 mm = 50 N
- Use the attached GRAPH PAPER.
- 2.4.3 Calculate the mass of the engine. (2)

[27]



**QUESTION 3 (Start on a new page.)**

- 3.1 Two bullets are fired, one from a pistol and the other from a rifle, as shown in the diagram below. Assume that the pistol and the rifle exert the same force on two identical bullets.

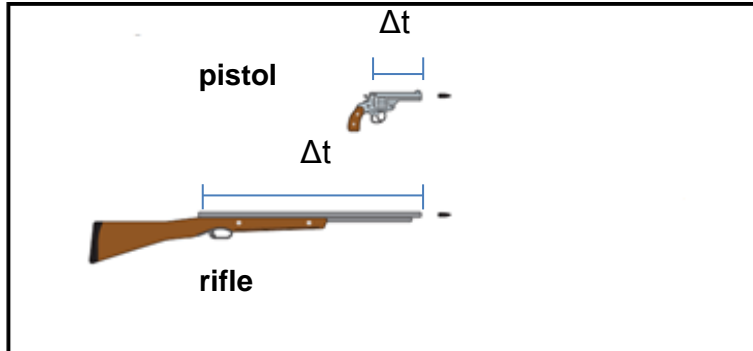

- 3.1.1 State Newton's Third Law in words. (2)
- 3.1.2 When the shot is fired, which bullet will have the greater change in momentum? Write down only FROM THE PISTOL or FROM THE RIFLE. Explain the answer. (3)
- 3.2 The rifle has a mass of 1,2 kg and the bullet a mass of 0,03 kg. The bullet leaves the rifle at a speed of 330 m.s<sup>-1</sup>.
- 3.2.1 State the principle of conservation of linear momentum in words. (2)
- 3.2.2 Calculate the velocity at which the rifle recoils (kicks back) when the shot is fired. (5)
- 3.2.3 Distinguish between the concepts *elastic* and *inelastic collisions*. (4)
- 3.3 A firefighter, with mass 70 kg, jumps from the roof of a building. He hits the ground at a velocity of 12,5 m.s<sup>-1</sup>. It takes him 0,03 s to come to a standstill.
- Calculate the force exerted onto his legs by the Earth. (4)

**[20]**



**QUESTION 4 (Start on a new page.)**

The top of a waterfall is 948 m high.  $6 \times 10^4$  kg of water falls from the top of the waterfall. (Ignore air resistance and any other frictional forces.)

- 4.1 Define *gravitational potential energy*. (2)
- 4.2 Calculate the gravitational potential energy of  $6 \times 10^4$  kg of water at the top of the waterfall. (3)
- 4.3 A pendulum is suspended by a string, as shown in the diagram below. It is pulled sideways and released. At the highest point of its swing, the pendulum bob is 25 cm above the floor. At the lowest point of its swing, the pendulum bob is 5 cm above the floor. The mass of the pendulum bob is 220 g.

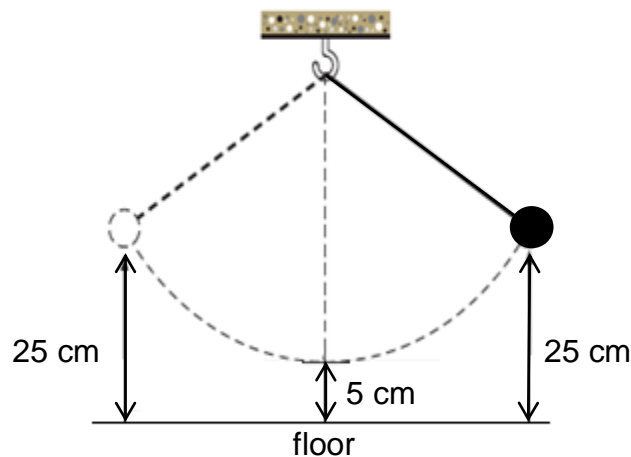

- 4.3.1 What is the mechanical energy of the pendulum, relative to the floor, when the bob is at its highest point? (4)
- 4.3.2 What is the mechanical energy of the pendulum, relative to the floor, when the bob is at its lowest point? (2)
- 4.3.3 What is the speed of the pendulum bob when the bob is at its lowest point? (4)

**[15]**

**QUESTION 5 (Start on a new page.)**

- 5.1 A load of 40 kN causes a compressive stress of 16 MPa in a square brass bar. Young's modulus for brass is 90 GPa. The original length of the bar is 300 mm.

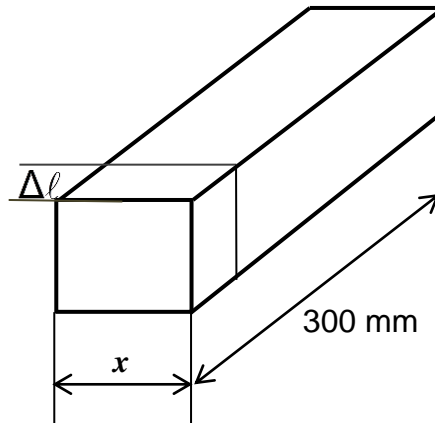

Determine, by means of calculations, the following:

- 5.1.1 The length,  $x$ , of one side of the square brass bar. Give your answer in millimetres. (5)
- 5.1.2 The strain caused by the load (3)
- 5.1.3 The change in length, in millimetres, caused by the load (3)



- 5.2 A hydraulic system is being used to put machine parts into position during the assembling process of a machine.

Specifications of the system: Piston **A** has a diameter of 50 mm and Piston **B** a diameter of 200 mm.

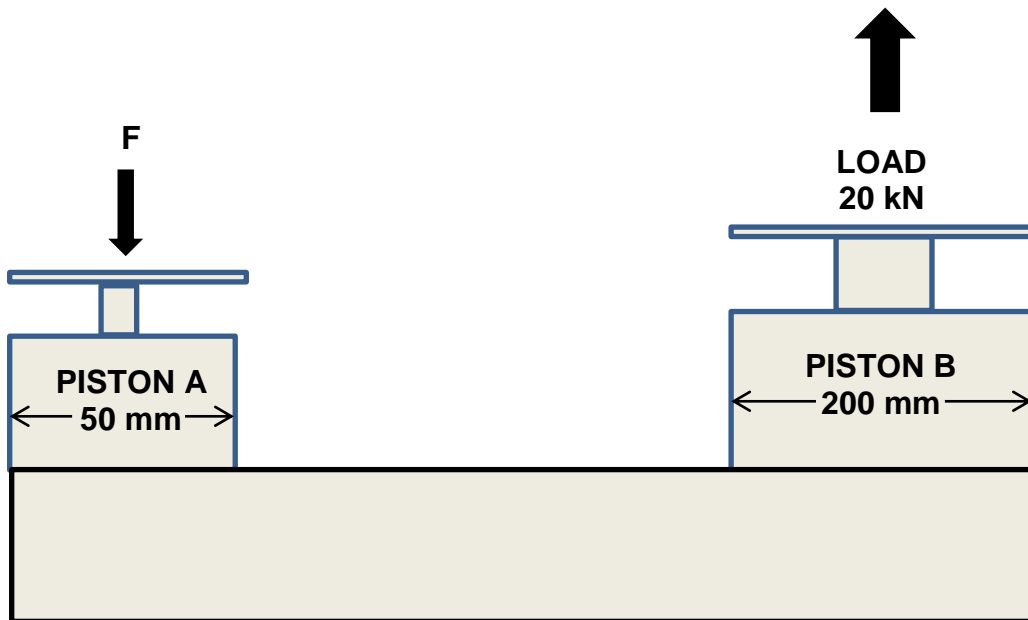

Calculate:

- 5.2.1 The fluid pressure in the hydraulic system when in equilibrium (4)
- 5.2.2 The force,  $F$ , that must be exerted onto Piston **A** with an area of  $1,96 \times 10^{-3} \text{ m}^2$  to lift the load of 20 kN on Piston **B** (4)

[19]



**QUESTION 6 (Start on a new page.)**

The diagram below shows the path of a light beam through a rectangular glass block. Answer the questions that follow.

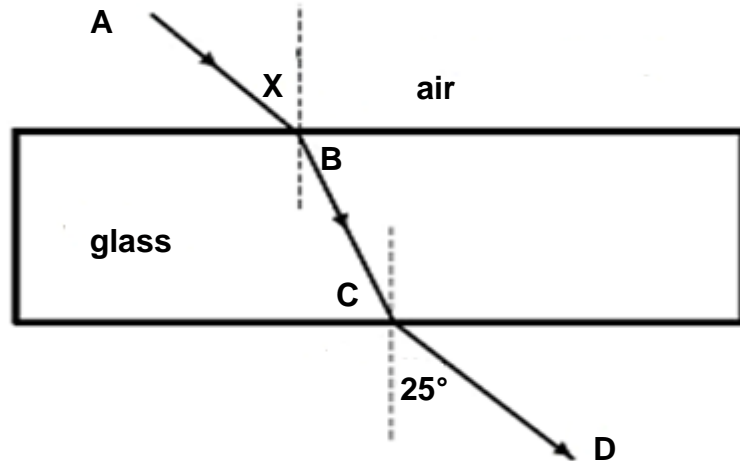

- 6.1 Define *refraction*. (2)
- 6.2 Name angle **X**. (1)
- 6.3 Write down the value of angle **X**. (1)
- 6.4 Name the angle marked as  $25^\circ$ . (1)
- 6.5 How is the speed of the light ray affected as it moves from the glass block into the air? Write down only INCREASES, DECREASES or NO EFFECT. (1)
- 6.6 Name the following rays:
  - 6.6.1 **AB** (1)
  - 6.6.2 **BC** (1)
  - 6.6.3 **CD** (1)
- 6.7 Which ONE of the two media, AIR or GLASS, is optically denser?  
Give a reason for the answer. Refer to the NORMAL and SPEED OF LIGHT. (3)
- 6.8 State THREE uses of total internal reflection. (3)

**[15]**



**QUESTION 7 (Start on a new page.)**

- 7.1 The electromagnetic spectrum consists of seven radiation rays. List any FOUR of the seven rays in no particular order. (4)
- 7.2 Write down the rays that:
- 7.2.1 Lead to skin damage when a person is overexposed to sunlight (1)
  - 7.2.2 Are used in night-vision devices (1)
  - 7.2.3 Can penetrate the human body to gather medical information (1)
  - 7.2.4 Have photons with the lowest energy (1)
- [8]**

**QUESTION 8 (Start on a new page.)**

- 8.1 A 3 V battery is connected to a circuit, as shown below.

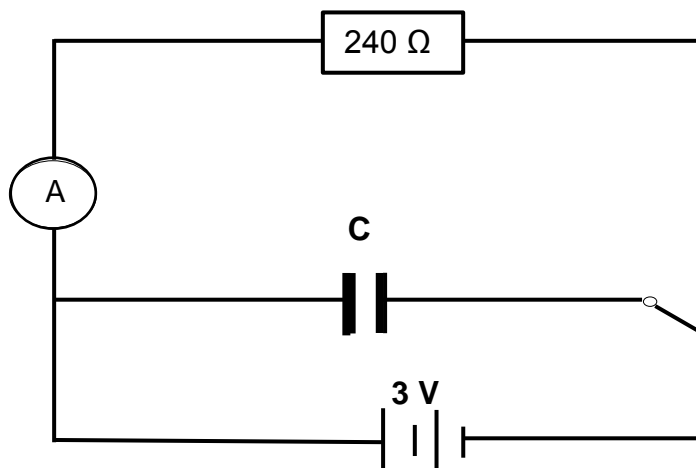

- 8.1.1 State whether capacitor **C** will charge or discharge according to the diagram. Write down only CHARGE or DISCHARGE. (1)
  - 8.1.2 Give a reason for the answer to QUESTION 8.1.1. (1)
- 8.2 The plates of a parallel-plate capacitor are 2,38 mm apart and each has an area of 10,2 cm<sup>2</sup>. Each plate carries a charge of 0,345 nC.
- Calculate:
- 8.2.1 The capacitance of this capacitor (3)
  - 8.2.2 The potential difference between the plates (3)
- [8]**



**QUESTION 9 (Start on a new page.)**

- 9.1 A current of 6 A is flowing through an electrical appliance with a potential difference of 220 V.
- 9.1.1 Electrical power can be converted for household and other uses. Name TWO of these conversions/uses of electrical power. (2)
- 9.1.2 Calculate the power dissipated in the electrical appliance. (3)
- 9.2 Two ohmic resistors,  $R_1$  and  $R_2$ , are connected in series with a cell with negligible internal resistance. Find the value of  $R_2$ , given that the current flowing through  $R_1$  and  $R_2$  is 0,5 A and the potential difference across the cell is 1,5 V. The value of  $R_1$  is  $2 \Omega$ .

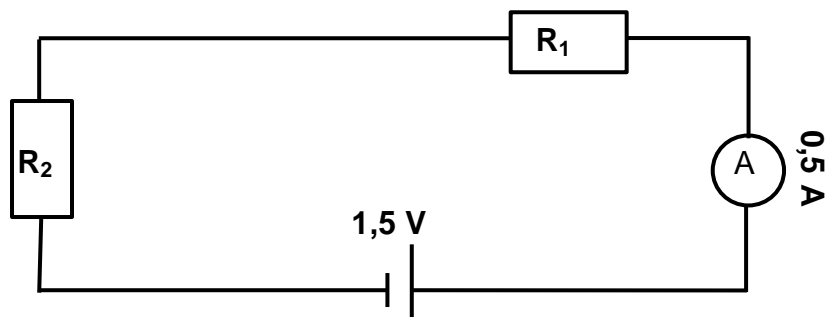

(4)  
[9]



**QUESTION 10 (Start on a new page.)**

10.1 Study the diagram of the DC motor shown below. Answer the questions that follow.

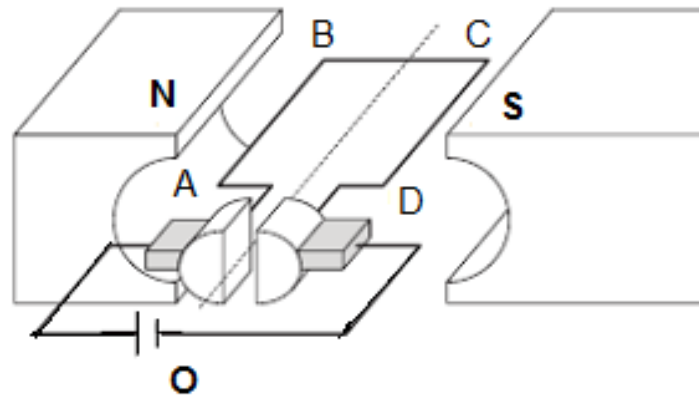

10.1.1 Define an *electric motor*. (2)

10.1.2 Name ONE characteristic that makes this a DC motor. (1)

10.1.3 State whether the coil will rotate CLOCKWISE or ANTI-CLOCKWISE. Assume that the coil is observed from point O. (1)

10.2 State the energy conversion that takes place in an AC generator. (2)

10.3 A transformer has 1 500 secondary turns and 250 primary turns. If the secondary voltage is 240 V, determine the primary voltage. (3)  
[9]

**TOTAL: 150**



**DATA FOR TECHNICAL SCIENCES GRADE 12  
PAPER 1**

**GEGEWENS VIR TEGNIESE WETENSKAPPE GRAAD 12  
VRAESTEL 1**

**TABLE 1: PHYSICAL CONSTANTS/TABEL 1: FISIESE KONSTANTES**

| NAME/NAAM  | SYMBOL/SIMBOOL | VALUE/WAARDE                             |
|--|----------------|--|
| Acceleration due to gravity<br><i>Swaartekragversnelling</i>       | g              | 9,8 m·s <sup>-2</sup>                    |
| Speed of light in a vacuum<br><i>Spoed van lig in 'n vakuum</i>    | c              | 3,0 x 10 <sup>8</sup> m·s <sup>-1</sup>  |
| Planck's constant<br><i>Planck se konstante</i>                    | h              | 6,63 x 10 <sup>-34</sup> J·s             |
| Electron mass<br><i>Elektronmassa</i>                              | m <sub>e</sub> | 9,11 x 10 <sup>-31</sup> kg              |
| Permittivity of free space<br><i>Permittiwiteit van vry ruimte</i> | ε <sub>o</sub> | 8,85x10 <sup>-12</sup> F.m <sup>-1</sup> |

**TABLE 2: FORMULAE/TABEL 2: FORMULES**

**FORCE/KRAG**

|   |                 |
|---|-----------------|
| $F_{net} = ma$  | $p = mv$        |
| $f_s^{max} = \mu_s N$                                     | $f_k = \mu_k N$ |
| $F_{net} \Delta t = \Delta p$<br>$\Delta p = mv_f - mv_i$ | $F_g = mg$      |

**WORK, ENERGY AND POWER/ARBEID, ENERGIE EN DRYWING**

|   |                             |
|---|-----------------------------|
| $W = F\Delta x \cos \theta$                           | $U = mgh$ or/of $E_p = mgh$ |
| $K = \frac{1}{2} mv^2$ or/of $E_k = \frac{1}{2} mv^2$ | $P = \frac{W}{\Delta t}$    |
| $P_{ave} = Fv_{ave}$ / $P_{gemid} = Fv_{gemid}$       | $M_E = E_k + E_p$           |



**ELASTICITY, VISCOSITY AND HYDRAULICS/ELASTISITEIT, VISKOSITEIT EN HIDROULIKA**

|                               |                                     |
|-------------------------------|-------------------------------------|
| $\sigma = \frac{F}{A}$        | $\epsilon = \frac{\Delta l}{L}$     |
| $\frac{\sigma}{\epsilon} = K$ | $\frac{F_1}{A_1} = \frac{F_2}{A_2}$ |
| $P = \frac{F}{A}$             | $P = \rho gh$                       |

**ELECTROSTATICS/ELEKTROSTATIKA**

|   |                              |
|---|------------------------------|
| $F = \frac{kQ_1Q_2}{r^2}$                   | $E = \frac{kQ}{r^2}$         |
| $Q = \frac{Q_1 + Q_2}{2}$                   | $E = \frac{F}{q}$            |
| $n = \frac{Q}{e}$ or/of $n = \frac{Q}{q_e}$ | $E = \frac{V}{d}$            |
| $C = \frac{Q}{V}$                           | $C = \frac{\epsilon_0 A}{d}$ |

**CURRENT ELECTRICITY/STROOMELEKTRISITEIT**

|   |  |
|---|--|
| $R = \frac{V}{I}$   | $\text{emf/emk} (\mathcal{E}) = I(R + r)$                                  |
| $R_s = R_1 + R_2 + \dots$<br>$\frac{1}{R_p} = \frac{1}{R_1} + \frac{1}{R_2} + \dots$  | $q = I \Delta t$   |
| $W = VQ$<br>$W = VI \Delta t$<br>$W = I^2 R \Delta t$<br>$W = \frac{V^2 \Delta t}{R}$ | $P = \frac{W}{\Delta t}$<br>$P = VI$<br>$P = I^2 R$<br>$P = \frac{V^2}{R}$ |



**ELECTROMAGNETISM/ELEKTROMAGNETISME**

|                                     |   |
|-------------------------------------|---|
| $\phi = BA$                         | $\epsilon = -N \frac{\Delta\phi}{\Delta t}$ |
| $\frac{V_s}{V_p} = \frac{N_s}{N_p}$ |   |

**WAVES, SOUND AND LIGHT**

|  |                   |
|--|-------------------|
| $v = f \lambda$                          | $T = \frac{1}{f}$ |
| $E = hf$ or/of $E = h \frac{c}{\lambda}$ |                   |



|                       |  |  |  |  |  |  |  |  |
|-----------------------|--|--|--|--|--|--|--|--|
| <b>CENTRE NUMBER:</b> |  |  |  |  |  |  |  |  |
|-----------------------|--|--|--|--|--|--|--|--|

|                            |  |  |  |  |  |  |  |  |  |  |  |  |  |
|----------------------------|--|--|--|--|--|--|--|--|--|--|--|--|--|
| <b>EXAMINATION NUMBER:</b> |  |  |  |  |  |  |  |  |  |  |  |  |  |
|----------------------------|--|--|--|--|--|--|--|--|--|--|--|--|--|

|                       |
|-----------------------|
| <b>QUESTION 2.4.2</b> |
|-----------------------|

