

Confidential



basic education

Department:
Basic Education
REPUBLIC OF SOUTH AFRICA

SENIOR CERTIFICATE EXAMINATIONS/ NATIONAL SENIOR CERTIFICATE EXAMINATIONS

TECHNICAL MATHEMATICS P1

MAY/JUNE 2025

MARKS: 150

TIME: 3 hours

**This question paper consists of 11 pages, a 2-page information sheet and
a 21-page SPECIAL ANSWER BOOK.**



INSTRUCTIONS AND INFORMATION

Read the following instructions carefully before answering the questions.

1. This question paper consists of NINE questions.
2. Answer ALL the questions in the SPECIAL ANSWER BOOK provided.
3. Number the answers correctly according to the numbering system used in this question paper.
4. Clearly show ALL calculations, diagrams, graphs, etc. that you have used in determining your answers.
5. Answers only will NOT necessarily be awarded full marks.
6. You may use an approved scientific calculator (non-programmable and non-graphical), unless stated otherwise.
7. If necessary, round off answers to TWO decimal places, unless stated otherwise.
8. Diagrams are NOT necessarily drawn to scale.
9. An information sheet with formulae is included at the end of the question paper.
10. Write neatly and legibly. _



QUESTION 11.1 Solve for x :

1.1.1 $(4x + 1)(5 - x) = 0$ (2)

1.1.2 $x(7x - 9) - 8 = 0$ (correct to TWO decimal places) (4)

1.1.3 $-x^2 + 5x + 6 > 0$ (express the solution in interval notation) (3)

1.2 Given: $y - 2x = 1$ and $x^2 - xy + y^2 = 7$

1.2.1 Make y the subject of the formula if $y - 2x = 1$ (1)

1.2.2 Hence, solve for x and y . (5)

1.3 The formula used to determine synchronous speed in revolutions per minute (r/min) is given below:

$$N_s = \frac{60 \times f}{P}$$

Where:

 N_s = synchronous speed (in r/min) f = frequency (in hertz) P = number of poles

1.3.1 Make P the subject of the formula. (1)

1.3.2 Hence, calculate the numerical value of P if $N_s = 540$ r/min and $f = 63$ hertz. (2)

1.4 Given: $Q = 15$ and $R = 4Q$

Evaluate $\frac{R}{110_2}$ and give your answer in binary form. (3)

[21]

QUESTION 2

- 2.1 Given the equation: $x^2 - 4 = 0$
- 2.1.1 Determine the numerical value of the discriminant. (2)
- 2.1.2 Hence, describe the nature of the roots of the equation. (2)
- 2.2 Determine the numerical value of p for which the equation $px^2 - 6x + 1 = 0$ will have equal roots. (4)
- [8]**

QUESTION 3

- 3.1 Simplify the following **without the use of a calculator**:
- 3.1.1 $\log_2 2^b$ (1)
- 3.1.2 $\frac{5^{3n} - 5^{3n-1}}{5^{3n+1}}$ (3)
- 3.1.3 $\frac{\sqrt{20x} \left(\sqrt{5x^3} + 3\sqrt[4]{625x^{12}} \right)}{2x}$ (5)
- 3.2 Solve for x : $\log(x + 3) = 1 + \log x$ (5)
- 3.3 Simplify $\sqrt{-16} + 3i^2$ in the form $a + bi$. (2)
- 3.4 Given the complex number: $z = i^7 + \sqrt{3}$
- 3.4.1 Simplify: $z = i^7 + \sqrt{3}$ (1)
- 3.4.2 Determine the modulus of z . (2)
- 3.4.3 Hence, express z in polar form. (Show ALL working.) (3)
- [22]**



QUESTION 4

4.1 Given the function defined by $h(x) = -\frac{3}{x} - 4$

4.1.1 Write down the equations of the asymptotes of h . (2)

4.1.2 Determine the x -intercept of h . (2)

4.1.3 Draw, on the grid provided in the SPECIAL ANSWER BOOK, the sketch graph of h . Clearly indicate intercepts with the axes and the asymptote. (3)

4.2 Draw, on the grid provided in the SPECIAL ANSWER BOOK, the sketch graph of the function defined by $k(x) = a^x + p$ with the following conditions:

- $0 < a < 1$
- $k(x) \neq -9$
- $k(0) = -8$
- $k(-2) = 0$ (4)



- 4.3 The sketch below represents functions f and g defined by $f(x) = x^2 - 4x - 5$ and $g(x) = mx + c$
 A and B are x -intercepts of f .
 C is the y -intercept of f and g .
 D is the turning point of f .
 Line ED is perpendicular to the x -axis.
 The graphs of f and g intersect at C and B.

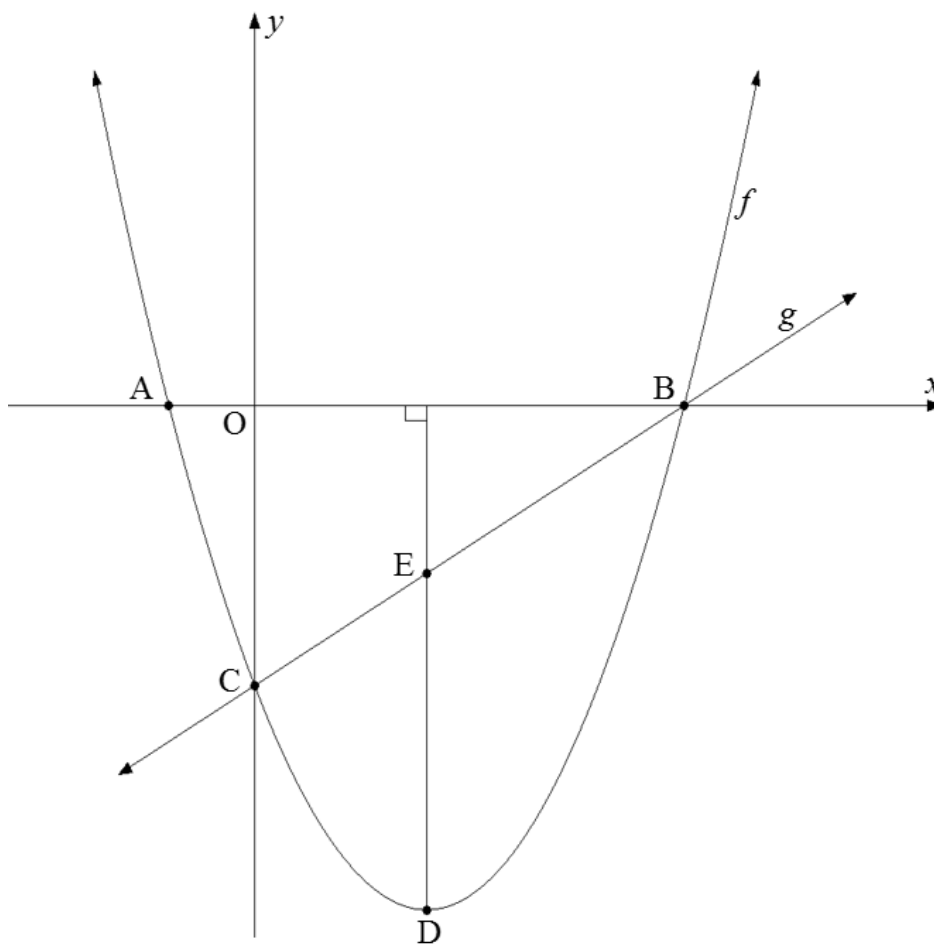

- 4.3.1 Write down the coordinates of C. (2)
 4.3.2 Determine the length of AB. (4)
 4.3.3 Determine the coordinates of D. (3)
 4.3.4 Write down the range of f . (1)
 4.3.5 Determine the equation of g . (3)
 4.3.6 Determine the length of ED. (2)

[26]



QUESTION 5

- 5.1 A mechanic bought a trolley jack for R10 063 and paid a deposit of R1 000. The balance owing was to be paid over a period of 24 months in equal monthly instalments of R464,48, using simple interest.

Calculate:

- 5.1.1 The total amount paid over 24 months (1)
- 5.1.2 The interest rate charged per annum (4)
- 5.2 The value of a car depreciates at a rate of 23% per annum, using the reducing-balance method. Calculate the book value (depreciated value) of the car at the end of 3 years if it was bought for R220 000. (3)
- 5.3 A company invested an amount of R40 000 for seven years.
- The interest earned for the first four years is 6,5% per annum, compounded quarterly.
 - Thereafter, the compounded amount was reinvested for another three years at 8% per annum, compounded half-yearly.

Determine whether the total interest earned for the investment would be less than half of the original amount. (6)

[14]



QUESTION 6

- 6.1 Given: $f(x) = -8x$
Determine $f'(x)$ using FIRST PRINCIPLES. (5)
- 6.2 Determine: $D_x[-2]$ (1)
- 6.3 Given: $f(x) = x^{\frac{3}{2}} - 4x^{-7}$
Determine $f'(x)$. (2)
- 6.4 Given: $y - yx = x^2 - 1$
- 6.4.1 Make y the subject of the equation and simplify completely. (4)
- 6.4.2 Hence, determine $\frac{dy}{dx}$. (1)
- 6.5 Given: $g(x) = 3x^2 + 5x$
- 6.5.1 Determine $g'(x)$. (2)
- 6.5.2 Determine $g'(-4)$. (1)
- 6.5.3 Hence, determine the equation of the tangent to g at $x = -4$ (3)
- 6.6 Determine the numerical value of k if the average gradient of a function between the points $(1; -6)$ and $(k; k-3)$ is equal to 5. (3)
- [22]



QUESTION 7

Given: $f(x) = -x^3 - 5x^2 + 24x$

- 7.1 Write down the y -intercept of f . (1)
- 7.2 Factorise $f(x)$ completely. (2)
- 7.3 Hence, write down the x -intercepts of f . (1)
- 7.4 Determine the coordinates of the turning points of f . (5)
- 7.5 Sketch the graph of f on the grid provided in the SPECIAL ANSWER BOOK. (3)
- 7.6 Use your graph to determine the values of x for which $x \times f'(x) > 0$ (3)
- [15]**



QUESTION 8

The diagram below shows an open rectangular box with the following dimensions in centimetres:

$$\text{Length} = 10 - 2x$$

$$\text{Breadth} = 2x + 2$$

$$\text{Height} = h$$

The breadth of the box is TWICE its height.

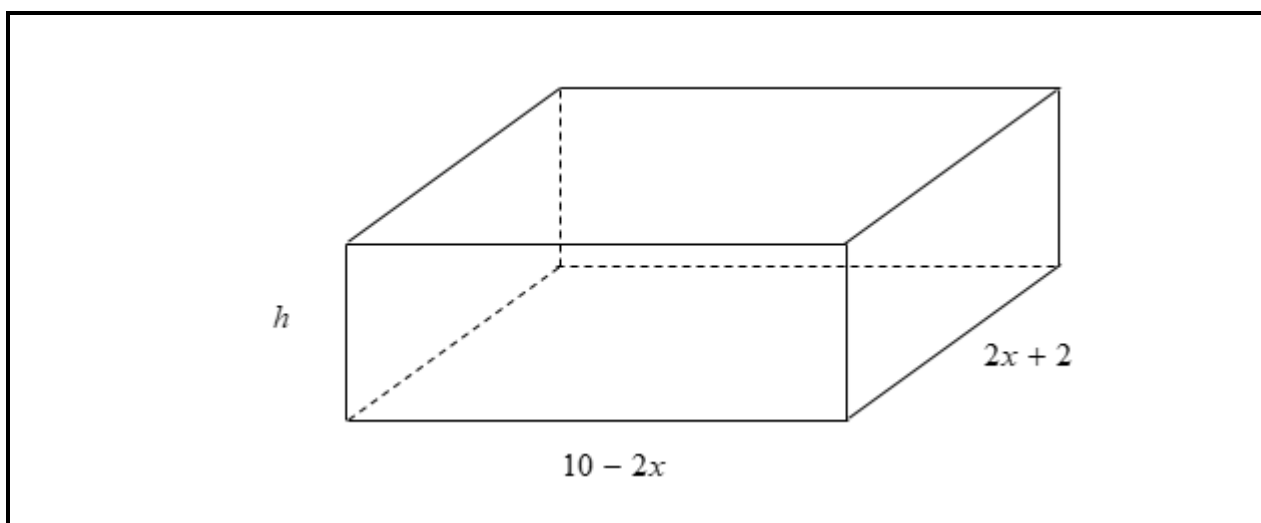

The following formula may be used:

$$\text{Volume of a rectangular prism} = l \times b \times h$$

- 8.1 Express the height of the box in terms of x . (1)
- 8.2 Hence, show that the volume of the box is $V(x) = -4x^3 + 12x^2 + 36x + 20$ (2)
- 8.3 Determine $V'(x)$. (1)
- 8.4 Hence, determine the value of x for which the volume of the box will be a maximum. (4)
- [8]



QUESTION 9

9.1 Determine $\int -5x^9 dx$. (2)

9.2 Given the expression: $\frac{2 - 8x^{-3} + x}{x}$

9.2.1 Simplify $\frac{2 - 8x^{-3} + x}{x}$. (2)

9.2.2 Hence, determine $\int \frac{2 - 8x^{-3} + x}{x} dx$. (3)

9.3 The sketch below represents the function defined by $f(x) = 4x^3$. The shaded area that is bounded by the curve of f , the x -axis and the ordinates $x = k$ and $x = 2k$ is equal to 36 015 square units.

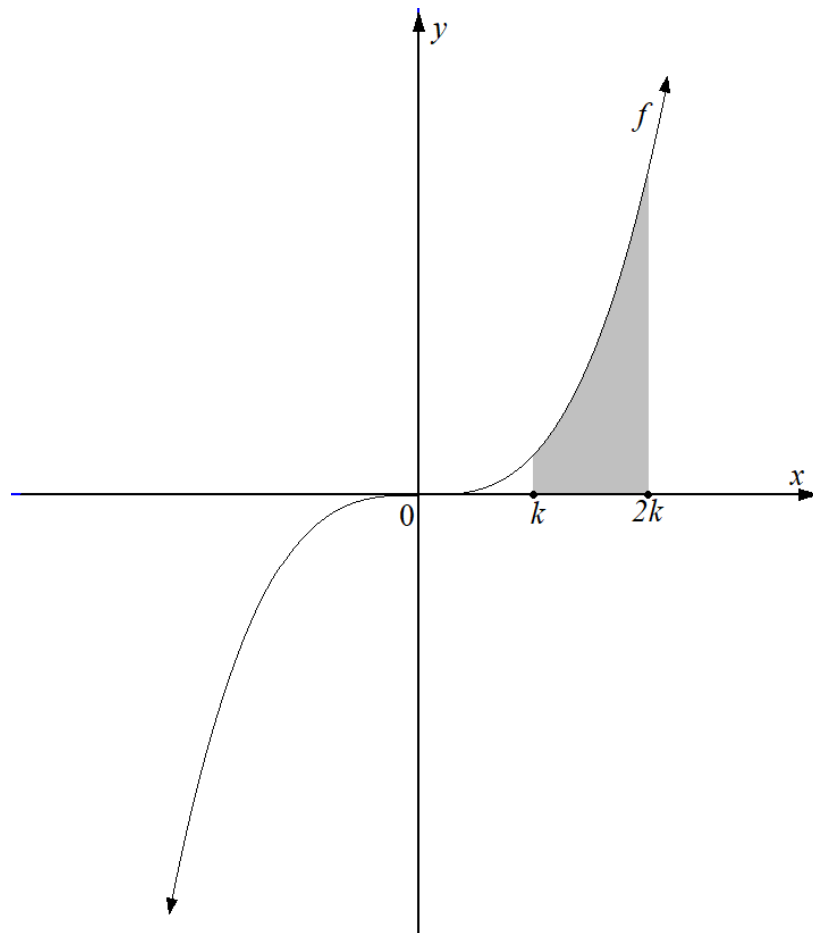

It was claimed to a Technical Mathematics class that the value of $2k$ lies between 10 and 20. Determine, showing ALL calculations, whether the claim is valid.

(7)
[14]

TOTAL: 150



INFORMATION SHEET: TECHNICAL MATHEMATICS

$$x = \frac{-b \pm \sqrt{b^2 - 4ac}}{2a} \qquad x = -\frac{b}{2a} \qquad y = \frac{4ac - b^2}{4a}$$

$$a^x = b \Leftrightarrow x = \log_a b, \quad a > 0, a \neq 1 \text{ and } b > 0$$

$$A = P(1 + ni) \qquad A = P(1 - ni) \qquad A = P(1 + i)^n \qquad A = P(1 - i)^n$$

$$i_{eff} = \left(1 + \frac{i}{m}\right)^m - 1$$

$$f'(x) = \lim_{h \rightarrow 0} \frac{f(x+h) - f(x)}{h}$$

$$\int kx^n dx = \frac{kx^{n+1}}{n+1} + C, \quad n, k \in \mathbb{R} \text{ with } n \neq -1 \text{ and } k \neq 0$$

$$\int \frac{k}{x} dx = k \ln x + C, \quad x > 0 \text{ and } k \in \mathbb{R}; k \neq 0$$

$$\int k a^{nx} dx = \frac{k a^{nx}}{n \ln a} + C, \quad a > 0; a \neq 1 \text{ and } k, a \in \mathbb{R}; k \neq 0$$

$$d = \sqrt{(x_2 - x_1)^2 + (y_2 - y_1)^2} \qquad M\left(\frac{x_2 + x_1}{2}; \frac{y_2 + y_1}{2}\right)$$

$$y = mx + c \qquad y - y_1 = m(x - x_1) \qquad m = \frac{y_2 - y_1}{x_2 - x_1} \qquad \tan \theta = m$$

$$\frac{x^2}{a^2} + \frac{y^2}{b^2} = 1$$

$$\text{In } \Delta ABC: \frac{a}{\sin A} = \frac{b}{\sin B} = \frac{c}{\sin C} \qquad a^2 = b^2 + c^2 - 2bc \cdot \cos A$$

$$\text{Area of } \Delta ABC = \frac{1}{2} ab \cdot \sin C$$

$$\sin^2 \theta + \cos^2 \theta = 1$$

$$1 + \tan^2 \theta = \sec^2 \theta$$

$$1 + \cot^2 \theta = \operatorname{cosec}^2 \theta$$



$$\pi \text{ rad} = 180^\circ$$

Angular velocity = $\omega = 2 \pi n$ where n = rotation frequency

Circumferential velocity = $v = \pi D n$ where D = diameter and n = rotation frequency

Circumferential velocity = $v = \omega r$ where ω = angular velocity and r = radius

Arc length = $s = r\theta$ where r = radius and θ = central angle in radians

Area of a sector = $\frac{r s}{2}$ where r = radius, s = arc length

Area of a sector = $\frac{r^2 \theta}{2}$ where r = radius and θ = central angle in radians

$4h^2 - 4d h + x^2 = 0$ where h = height of segment, d = diameter of circle
and x = length of chord

$A_T = a(m_1 + m_2 + m_3 + \dots + m_n)$ where a = length of the equal parts, $m_1 = \frac{o_1 + o_2}{2}$
 $o_n = n^{\text{th}}$ ordinate and n = number of ordinates

OR

$A_T = a \left(\frac{o_1 + o_n}{2} + o_2 + o_3 + \dots + o_{n-1} \right)$ where a = length of the equal parts, $o_n = n^{\text{th}}$ ordinate
and n = number of ordinates

