



# basic education

Department:  
Basic Education  
**REPUBLIC OF SOUTH AFRICA**

## SENIOR CERTIFICATE EXAMINATIONS/ NATIONAL SENIOR CERTIFICATE EXAMINATIONS

**ENGINEERING GRAPHICS AND DESIGN P2**  
**MAY/JUNE 2025**

**MARKS: 100**

**TIME: 3 hours**

**This question paper consists of 6 pages.**

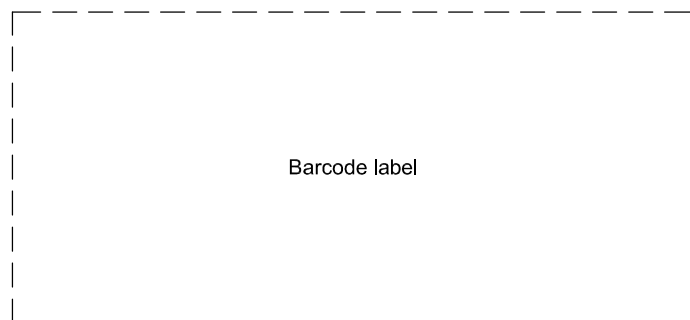

Barcode label

**DO NOT FOLD THE QUESTION PAPER IN HALF.**

### INSTRUCTIONS AND INFORMATION

1. This question paper consists of FOUR questions.
2. Answer ALL the questions.
3. ALL drawings are in third-angle orthographic projection, unless otherwise stated.
4. ALL drawings must be prepared using pencil and instruments, unless otherwise stated.
5. ALL answers must be drawn accurately and neatly.
6. ALL the questions must be answered on the QUESTION PAPER, as instructed.
7. ALL the pages, irrespective of whether the question was attempted or not, must be re-stapled in numerical sequence in the TOP LEFT-HAND CORNER ONLY.
8. Time management is essential in order to complete all the questions.
9. Print your examination number in the block provided on every page.
10. Any details or dimensions not given must be assumed in good proportion.

FOR OFFICIAL USE ONLY															
QUESTION	MARKS OBTAINED			$\frac{1}{2}$	SIGN	MODERATED			$\frac{1}{2}$	SIGN	RE-MARKING			$\frac{1}{2}$	SIGN
1															
2															
3															
4															
<b>TOTAL</b>															
	<b>2</b>	<b>0</b>	<b>0</b>			<b>2</b>	<b>0</b>	<b>0</b>			<b>2</b>	<b>0</b>	<b>0</b>		

FINAL CONVERTED MARK	CHECKED BY
<u>100</u>	

COMPLETE THE FOLLOWING:	
CENTRE NUMBER	
CENTRE NUMBER	
EXAMINATION NUMBER	
EXAMINATION NUMBER	

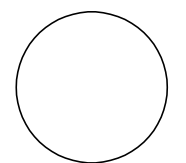

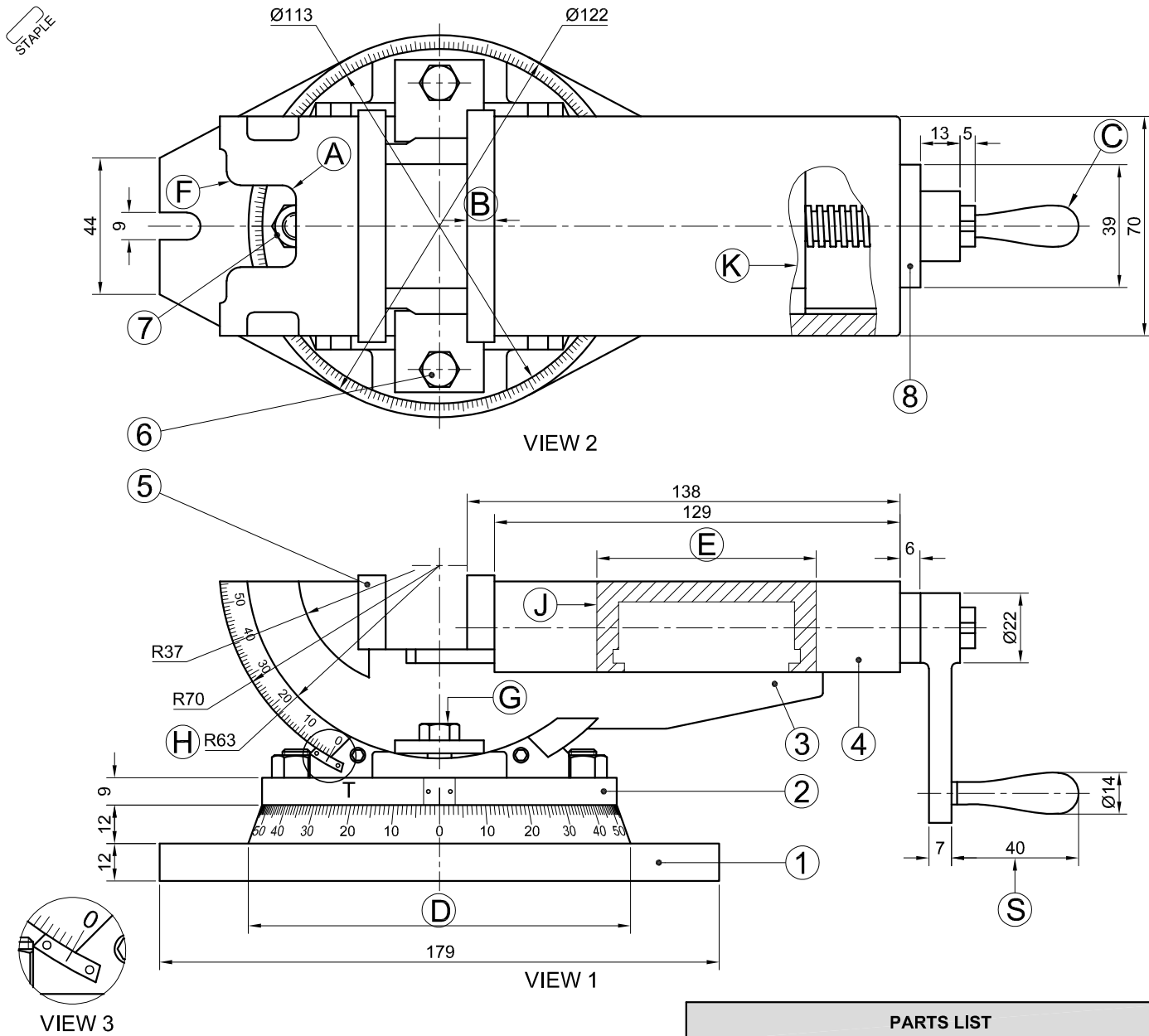

**QUESTION 1: ANALYTICAL (MECHANICAL)**

**Given:**  
Two views of a swivel vice, a welding symbol, a parts list, a title block and a table of questions. The drawing is not presented to the indicated scale.

**Instructions:**  
Complete the table below by neatly answering the questions, which refer to the accompanying drawing, title block and mechanical content. [30]

QUESTIONS		ANSWERS	
1	Who approved the drawing?	1	
2	What is the name of the company?	1	
3	Which drawing program was used to prepare the drawing?	1	
4	What projection system is indicated by the symbol in the title panel?	1	
5	From what material are the jaw plates made?	1	
6	How many M10 bolts are there in a single swivel vice assembly?	1	
7	At what temperature must the tempering be done?	1	
8	If VIEW 1 is the front view, what would VIEW 2 be called?	1	
9	What is the correct label for VIEW 3?	1	
10	Determine the complete dimensions at: A: B: C: D: E:	5	
11	Name the feature at F.	1	
12	Name the feature at G.	1	
13	If a scale of 1 : 1 was used, how would the dimension at H read?	1	
14	What type of section is shown at J?	1	
15	What type of section is shown at K?	1	
16	With reference to the welding symbol, what does M indicate?	1	
17	With reference to the welding symbol, what does '25 - 75' indicate?	25: 1 75: 1	
18	With reference to the tolerance, calculate the <b>maximum</b> and the <b>minimum</b> size of the dimension at S.	MAXIMUM: 1 MINIMUM: 1	
19	In the space below (ANSWER 19), complete, in neat freehand, the sectional view of the given mechanical part according to cutting plane A-A.	3	
20	With reference to the machining symbol in the space below (ANSWER 20), ONLY add the letters A, B and C to the symbol, in the correct position, that describe the given specifications...	3	
<b>TOTAL</b>		<b>30</b>	

PARTS LIST			
NO.	PARTS	QUANTITY	MATERIAL
1	BASE PLATE	1	CAST IRON
2	CRADLE	1	CAST IRON
3	SWIVEL JAW	1	CAST IRON
4	SLIDING JAW	1	CAST IRON
5	JAW PLATES	2	MILD STEEL
6	M10 BOLT	2	CAST IRON
7	M12 NUT	2	TOOL STEEL
8	ELLIPTICAL BRACKET	1	CAST IRON

**WELDING SYMBOL**

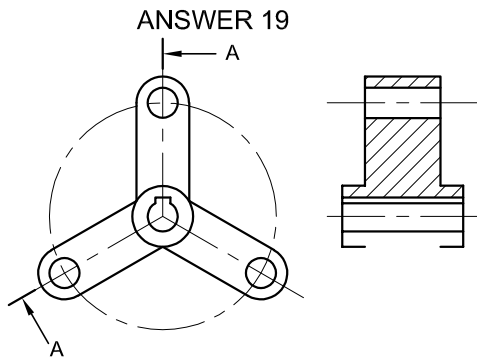
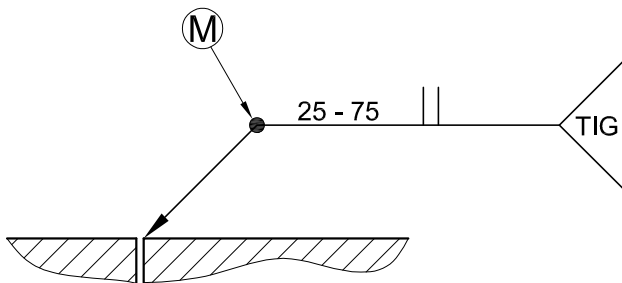

A = DIRECTION OF LAY  
B = ROUGHNESS VALUE  
C = METHOD

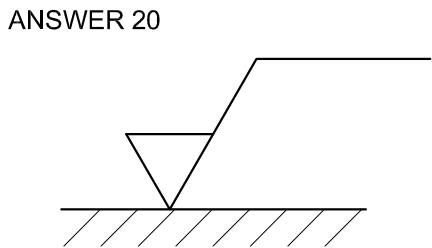

FILE NAME: KRJM314	DRAWING No. CLMP02	TOLERANCE: +0,23 -0,10	CLAMPIT TOOLS CC 4020 DAISY STREET POLOKWANE 0330 www.clamp.co.za cell: 090 131 4330	HEAT TREATMENT: TEMPERING AT 860° WITH INDUCTION HEATING
DRAWING PROGRAM: AUTOCAD 2024		SCALE 1 : 3		UNSPECIFIED RADII ARE R2.
DRAWN BY: ALISTER	DATE: 13/07/2024	TITLE: <b>SWIVEL VICE</b>		
CHECKED BY: ERIC	DATE: 14/08/2024			
APPROVED BY: SAMANTHA	DATE: 05/09/2024			

EXAMINATION NUMBER
EXAMINATION NUMBER
2

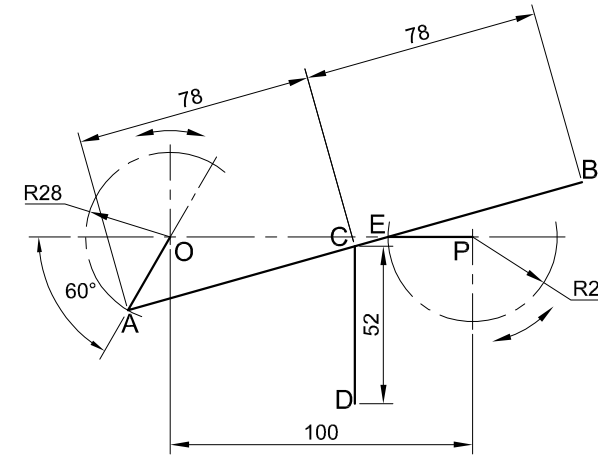

**QUESTION 2: LOCI**

**NOTE:** Answer QUESTIONS 2.1 and 2.2.

**2.1 MECHANISM**

**Given:**

- A schematic drawing of a mechanism consisting of crank OA, slotted link AB, rod CD and crank PE
- The position of centre point O on the drawing sheet

**Specifications:**

- Crank OA is pin-jointed to slotted link AB at A.
- End E of crank PE slides along the slot of link AB.
- Rod CD is pin-jointed to slotted link AB at C.

**Motion:**

As crank OA starts its oscillation in a clockwise direction through 180° around centre point O, crank PE starts its oscillation at the same speed through 180° in an anti-clockwise direction around centre point P.

During the movement, end E of crank PE reciprocates in the slot of link AB.

Rod CD remains vertical throughout the movement of the two cranks.

**Instructions:**

- Using centre point O, draw, to scale 1 : 1, the given schematic drawing, including the labels.
- Trace the loci generated by point B and point D for ONE oscillation.
- Show ALL construction. [20 1/2]

ASSESSMENT CRITERIA 2.1			
1	GIVEN + CL	7 1/2	
2	CONSTRUCTION	4	
3	LOCUS OF B	4 1/2	
4	LOCUS OF D	4 1/2	
PENALTIES (-)			
<b>SUBTOTAL</b>		<b>20 1/2</b>	

**2.2: CAM**

**Given:**

- The detail of a camshaft and a roller-follower at the minimum distance from the camshaft centre
- The displacement graph, correctly aligned for the given follower and camshaft

**Specifications:**

- The roller-follower reciprocates along the 30° centre line that passes through the centre of the camshaft.
- Roller = Ø12
- Rotation = clockwise

**Instructions:**

- Project and draw the cam profile from the given displacement graph.
- Indicate the direction of rotation on the cam profile with an arrow.
- Show ALL necessary construction and projection.
- In the space provided, name the type of motion from 135° to 225°. [19 1/2]

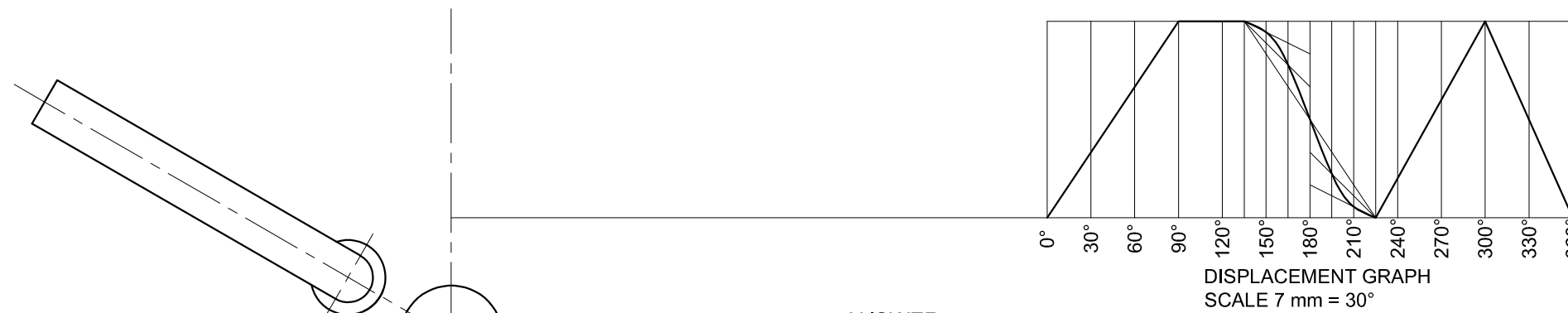

ANSWER  
MOTION FROM 135° TO 225°: \_\_\_\_\_

ASSESSMENT CRITERIA 2.2			
1	CONSTRUCTION	5	
2	CAM PROFILE	13 1/2	
3	TYPE OF MOTION	1	
PENALTIES (-)			
<b>SUBTOTAL 2.2</b>		<b>19 1/2</b>	
<b>SUBTOTAL 2.1</b>		<b>20 1/2</b>	
<b>TOTAL</b>		<b>40</b>	

EXAMINATION NUMBER	
EXAMINATION NUMBER	3





**QUESTION 3: ISOMETRIC DRAWING**

**Given:**

- The front view and top view of a gauge block
- The position of point P on the drawing sheet

**Instructions:**

Using scale 1 : 1, convert the orthographic views of the gauge block into a sectional isometric drawing on cutting plane S-S.

- Use P as the starting point and lowest point of the drawing.
- Show ALL construction.
- NO hidden detail is required. **[40]**

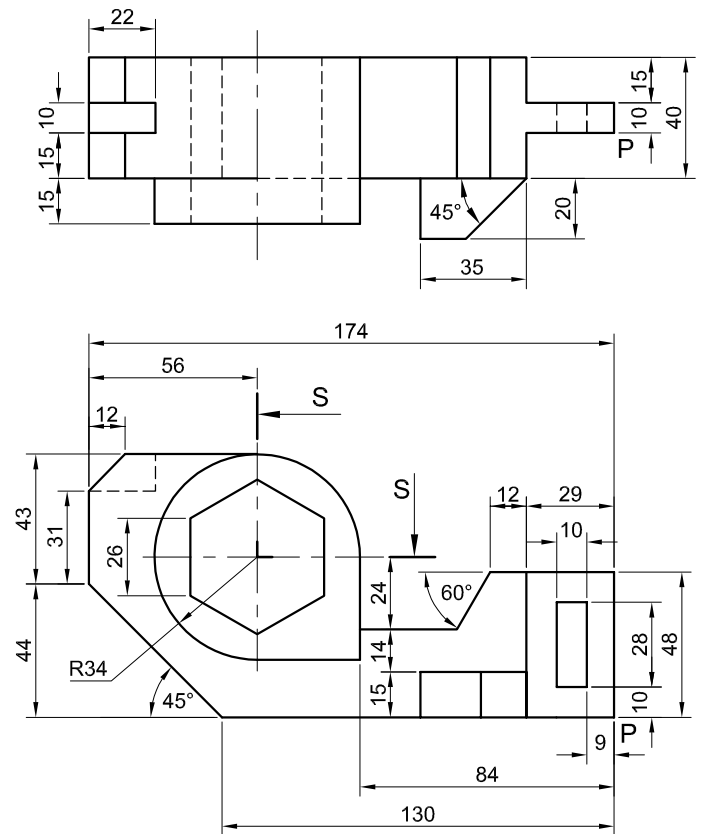

ASSESSMENT CRITERIA			
1	PLACING/ORIENTATION + AUX. VIEWS	2	
2	FRONT PORTION	16 1/2	
3	MIDDLE + REAR PORTION	7	
4	HEXAGON	4 1/2	
5	CIRCLE + CL	5	
6	SECTIONED SURFACE + HATCHING	5	
PENALTIES (-)			
<b>TOTAL</b>		<b>40</b>	
EXAMINATION NUMBER			
EXAMINATION NUMBER			
EXAMINATION NUMBER			<b>4</b>



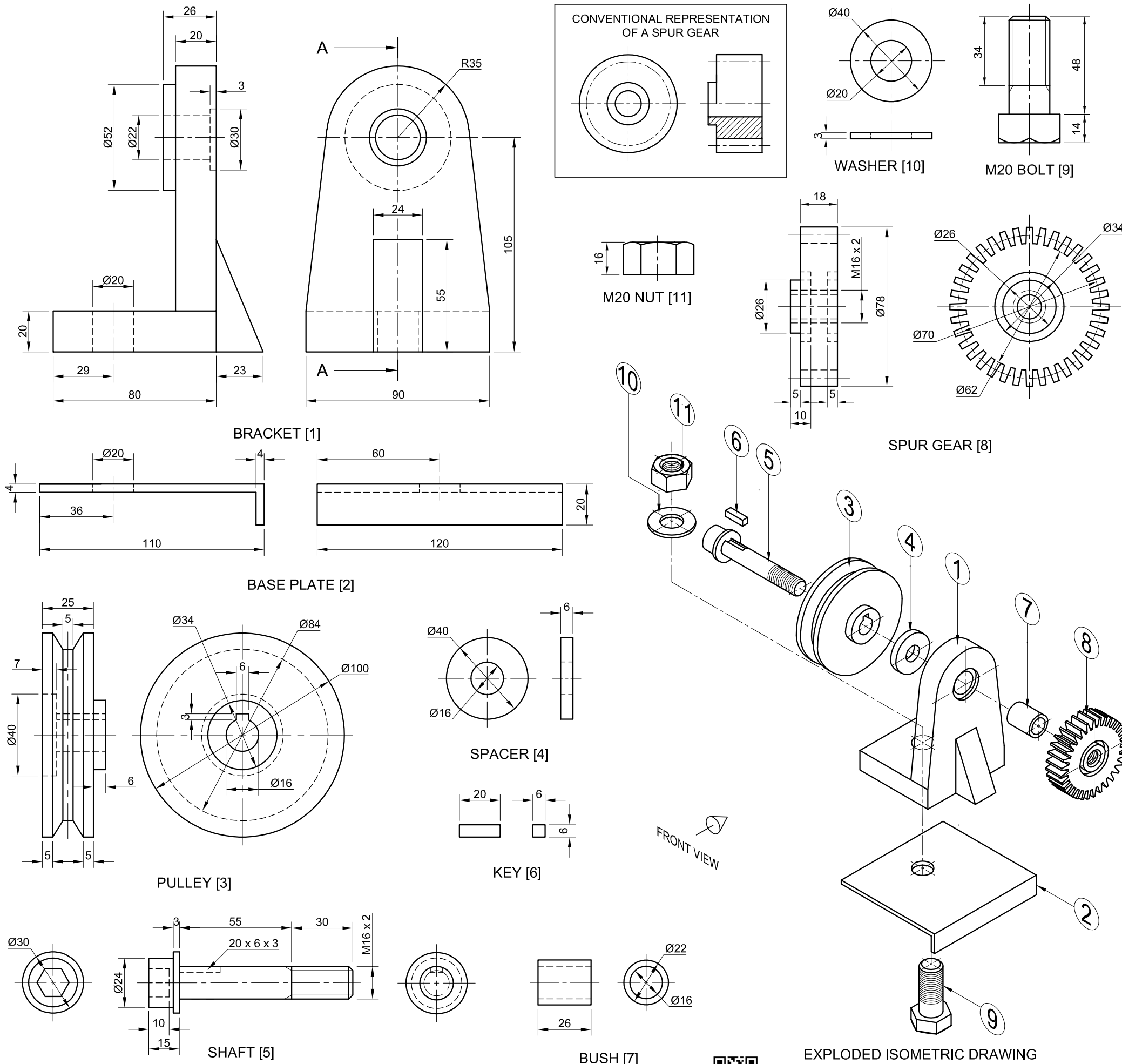

**QUESTION 4: MECHANICAL ASSEMBLY**

**Given:**

- Orthographic views of each part of a drive shaft support assembly
- The exploded isometric drawing of the parts of the drive shaft support assembly, showing the position of each part relative to all the others
- A conventional representation of a spur gear

**Instructions:**

- Answer this question on page 6.
- Draw, to scale 1 : 1 and in third-angle orthographic projection, the following views of the assembled parts of the drive shaft support assembly:
  - 4.1 **A sectional front view**, on cutting plane A-A, as seen from the direction of the arrow on the exploded isometric drawing. The cutting plane is shown on the right view of the bracket (part 1).
  - 4.2 **The right view**

**NOTE:**

- Planning is essential.
- ALL drawings must comply with the SANS 10111 guidelines.
- The convention of symmetry may NOT be applied.
- Show THREE faces of the M20 nut (part 11) and TWO faces of the M20 bolt head (part 9) in the front view.
- Show TWO faces of the hexagonal hole in the head of the shaft (part 5) in the front view.
- Draw the spur gear (part 8) as a conventional representation.
- Add cutting plane A-A.
- NO hidden detail is required.

[90]

PARTS LIST			
NO.	PART	QUANTITY	MATERIAL
1	BRACKET	1	MILD STEEL
2	BASE PLATE	1	MILD STEEL
3	PULLEY	1	CAST IRON
4	SPACER	1	MILD STEEL
5	SHAFT	1	STAINLESS STEEL
6	KEY	1	MILD STEEL
7	BUSH	1	BRASS
8	SPUR GEAR	1	STAINLESS STEEL
9	M20 BOLT	1	MILD STEEL
10	$\varnothing 40$ WASHER	1	SPRING STEEL
11	M20 NUT	1	MILD STEEL

**VBJW**  
ENGINEERING CC

25 AUGUSTUS AVE  
DAWNRIDGE  
www.dss.co.za  
062 292 9290

**DRIVE SHAFT SUPPORT**

ALL DIMENSIONS ARE IN MILLIMETRES.

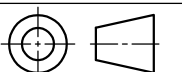

5

FOR OFFICIAL USE ONLY	
INCORRECT ORTHOGRAPHIC PROJECTION	
INCORRECT OVERALL SCALE	
INCORRECT HATCHING	
PARTS NOT ASSEMBLED	
TOTAL PENALTIES (-)	

ASSESSMENT CRITERIA					
RIGHT VIEW					
		POSSIBLE	OBTAINED	SIGN	MODERATED
1	BRACKET + BASE PLATE	5 $\frac{1}{2}$			
2	GEAR + CL	2			
3	PULLEY + SHAFT	2			
<b>SUBTOTAL</b>		<b>9 <math>\frac{1}{2}</math></b>			
SECTIONAL FRONT VIEW					
1	BASE	4			
2	BRACKET + RIB	10 $\frac{1}{2}$			
3	PULLEY	10			
4	SHAFT	11			
5	BUSH + KEY + SPACER	6 $\frac{1}{2}$			
6	SPUR GEAR	11			
7	M20 NUT + WASHER	5			
8	M20 BOLT	7 $\frac{1}{2}$			
<b>SUBTOTAL</b>		<b>65 <math>\frac{1}{2}</math></b>			
GENERAL					
1	CENTRE LINES	2			
2	CUTTING PLANE	3			
3	ASSEMBLY	10			
<b>SUBTOTAL</b>		<b>15</b>			
<b>TOTAL</b>		<b>90</b>			
PENALTIES (-)					
<b>GRAND TOTAL</b>					
EXAMINATION NUMBER					
EXAMINATION NUMBER					
6					

