

Confidential



basic education

Department:
Basic Education
REPUBLIC OF SOUTH AFRICA

SENIOR CERTIFICATE EXAMINATIONS/ NATIONAL SENIOR CERTIFICATE EXAMINATIONS

ELECTRICAL TECHNOLOGY: POWER SYSTEMS

MAY/JUNE 2025

MARKS: 200

TIME: 3 hours

This question paper consists of 19 pages and a 2-page formula sheet.



INSTRUCTIONS AND INFORMATION

1. This question paper consists of SEVEN questions.
2. Answer ALL the questions.
3. Sketches and diagrams must be large, neat and FULLY LABELLED.
4. Show ALL calculations and round off answers correctly to TWO decimal places.
5. Number the answers correctly according to the numbering system used in this question paper.
6. You may use a non-programmable calculator.
7. Calculations must include:
 - 7.1 Formulae and manipulations where needed
 - 7.2 Correct replacement of values
 - 7.3 Correct answer and relevant units where applicable
8. A formula sheet is attached at the end of this question paper.
9. Write neatly and legibly. ...



QUESTION 1: MULTIPLE-CHOICE QUESTIONS

Various options are provided as possible answers to the following questions. Choose the answer and write only the letter (A–D) next to the question numbers (1.1 to 1.15) in the ANSWER BOOK, e.g. 1.16 D.

- 1.1 A critical incident is an event where ...
- A a learner is injured without requiring first aid.
 - B pain is caused due to a soldering iron burn.
 - C a learner is injured and external emergency assistance is needed.
 - D the skin turns red when rinsing etching acid with water after a minor spillage. (1)
- 1.2 In an RLC series circuit, with the supply frequency far below the resonant frequency, the nature of the circuit's reactance is ...
- A more inductive.
 - B more capacitive.
 - C equal to the impedance.
 - D equal to the resistance. (1)
- 1.3 In an RLC series resonant circuit the ...
- A supply voltage is equal to the voltage across the inductor plus the voltage across the capacitor.
 - B voltage across the inductor and the capacitor are equal in magnitude and opposite in phase, resulting in their sum being zero.
 - C supply voltage is equal to the voltage across the resistor and inductor.
 - D voltage across the inductor and capacitor are both zero. (1)
- 1.4 The impedance of an RLC parallel resonant circuit is ...
- A at its maximum value.
 - B at its minimum value.
 - C equal to the difference between X_L and X_C .
 - D purely reactive. (1)
- 1.5 The instrument that indicates the ratio of the real power of the load to the apparent power from the supply is a/an ...
- A ammeter.
 - B energy meter.
 - C power factor meter.
 - D wattmeter. (1)



- 1.6 What effect does power factor correction have on the efficiency of three-phase electrical systems?
- A It decreases the efficiency by increasing losses.
 - B It has no effect on the efficiency.
 - C It improves the efficiency by increasing the voltage.
 - D It increases the efficiency. (1)
- 1.7 The primary function of a kilowatt-hour meter in an electrical system is to measure the ...
- A voltage in the system.
 - B current in the system.
 - C power factor of the system.
 - D energy consumption. (1)
- 1.8 In a transformer, the factor that contributes to the continuous degradation of its insulation is ...
- A a low input supply voltage.
 - B many windings around the core.
 - C an insufficient magnetic field.
 - D insufficient ventilation. (1)
- 1.9 The ... contribute(s) the highest percentage of the most common internal faults of three-phase transformers.
- A core
 - B windings
 - C bushing terminals
 - D oil conservator (1)
- 1.10 The reason for having skewed rotor bars in the rotor of an induction motor is to ...
- A reduce magnetic hum, keeping the motor quiet.
 - B decrease the effective ratio of transformation between the rotor and stator.
 - C decrease rotor resistance due to comparatively lengthier rotor conductor rods.
 - D decrease slip for a given torque. (1)
- 1.11 A/An ... is essential in a forward-reverse motor starter to enable the motor to reverse its direction of rotation.
- A circuit breaker
 - B overload relay
 - C second contactor
 - D second stop button (1)



- 1.12 The primary purpose of an automatic star-delta starter in a three-phase motor circuit is to ...
- A increase the speed of the motor.
 - B reduce the starting current of the motor.
 - C increase the phase voltage at start-up.
 - D convert AC power to DC power. (1)
- 1.13 In a PLC, ... refers to all the physical parts and components to form the device.
- A hardware
 - B software
 - C firmware
 - D ladder (1)
- 1.14 ... are virtual outputs used to hold data in the PLC program.
- A Timers
 - B Relays
 - C Contactors
 - D Markers (1)
- 1.15 In VSDs the ... is connected to the circuit to dissipate excessive regenerative energy.
- A filter
 - B inverter
 - C braking resistor
 - D converter (1)
- [15]**

QUESTION 2: OCCUPATIONAL HEALTH AND SAFETY

- 2.1 Define *health and safety equipment*. (2)
- 2.2 State TWO unsafe acts, regarding safety equipment, that are forbidden in an electrical technology workshop. (2)
- 2.3 State the purpose of the Occupational Health and Safety Act, 1993 (Act 85 of 1993). (2)
- 2.4 Explain why it is important for employers to inform employees about health and safety at the workplace. (2)
- 2.5 Briefly explain why discipline is considered an important work ethic with reference to the electrical technology workshop. (2)
- [10]**



QUESTION 3: RLC CIRCUITS

- 3.1 Explain the term *reactance* with reference to a pure inductive circuit. (2)
- 3.2 Refer to the circuit in FIGURE 3.2 below and answer the questions that follow.

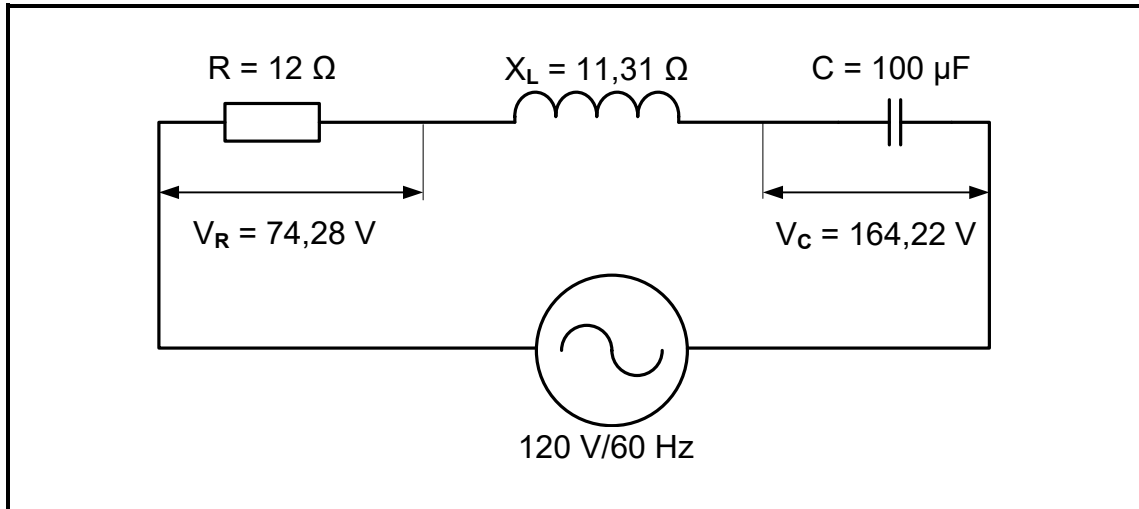

FIGURE 3.2: RLC SERIES CIRCUIT

Given:

- $V_T = 120 \text{ V}$
- $R = 12 \text{ } \Omega$
- $X_L = 11,31 \text{ } \Omega$
- $C = 100 \text{ } \mu\text{F}$
- $V_R = 74,28 \text{ V}$
- $V_C = 164,22 \text{ V}$
- $f = 60 \text{ Hz}$

Calculate the:

- 3.2.1 Capacitive reactance (3)
- 3.2.2 Total current (3)
- 3.2.3 Voltage across the inductor (3)
- 3.2.4 Capacitive value that will cause resonance (3)
- 3.3 Redraw and complete the phasor diagram in FIGURE 3.3 below. When labelling, use the relevant calculated values from the calculations above. (5)

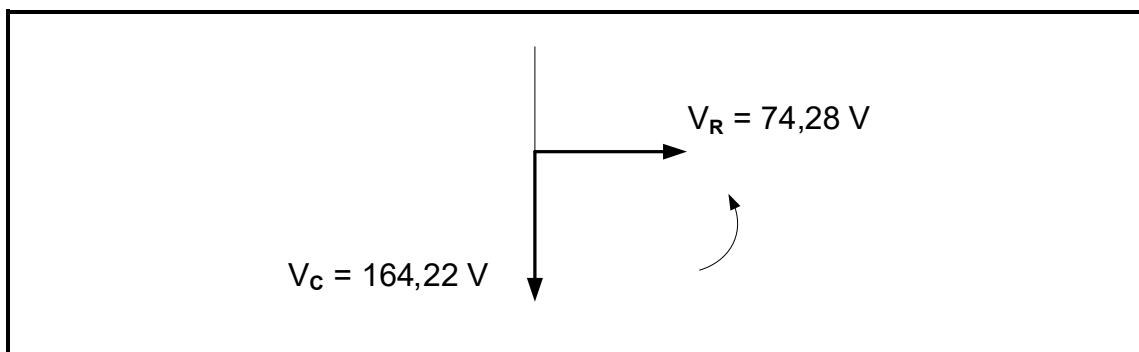

FIGURE 3.3



3.4 Refer to FIGURE 3.4 below and answer the questions that follow.

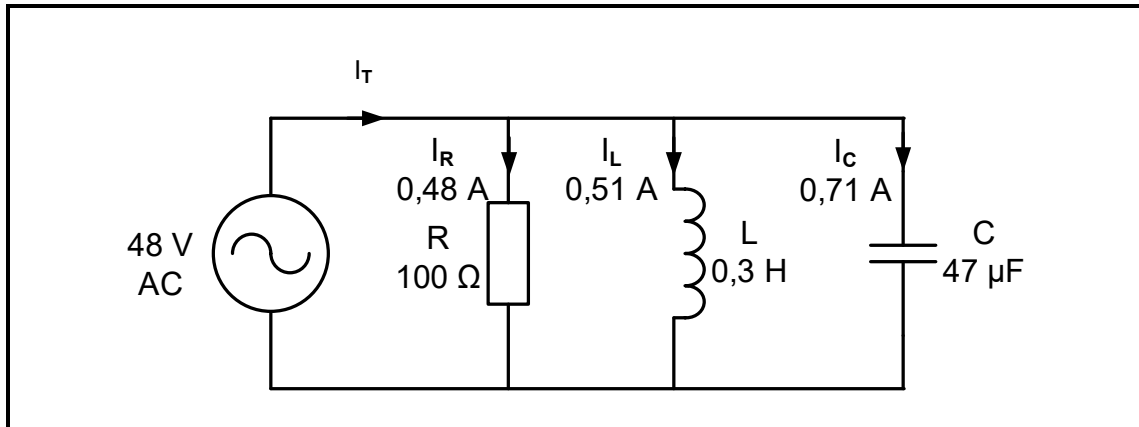

FIGURE 3.4: PARALLEL CIRCUIT

Given:

$$\begin{aligned}V_T &= 48 \text{ V} \\I_R &= 0,48 \text{ A} \\I_L &= 0,51 \text{ A} \\I_C &= 0,71 \text{ A} \\R &= 100 \text{ } \Omega \\L &= 0,3 \text{ H} \\C &= 47 \text{ } \mu\text{F}\end{aligned}$$

Calculate the:

- 3.4.1 Total current (3)
- 3.4.2 Phase angle (3)
- 3.4.3 Inductive reactance (3)
- 3.4.4 Supply frequency of the circuit (3)



3.5 FIGURE 3.5 below shows the Q-factor characteristic curve of an RLC circuit, NOT drawn to scale. Q_1 and Q_2 indicate how a change in the L/C ratio affects the Q-factor of a resonant circuit. Answer the questions that follow.

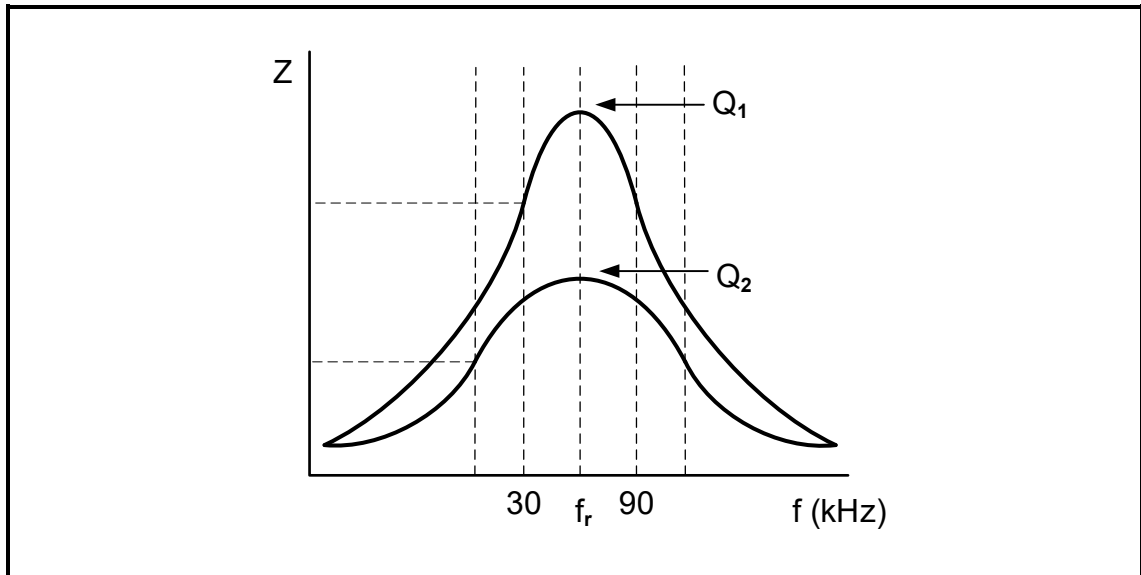

FIGURE 3.5: Q-FACTOR CHARACTERISTIC CURVE

- 3.5.1 Identify the curve with the widest bandwidth. (1)
 - 3.5.2 Calculate the resonant frequency for Q_1 . (3)
- [35]**



QUESTION 4: THREE-PHASE AC GENERATION

- 4.1 Name the main fuel source of Eskom's power stations in South Africa. (1)
- 4.2 In chronological order, name the TWO stages after generation in the South African National Power Grid. (2)
- 4.3 Explain how the voltage value of the power generated changes from the power station up to when it is used in domestic households in South Africa. (3)
- 4.4 A 30 kW delta-connected inductive load is powered from a three-phase supply with a line voltage of 400 V. It operates at a power factor of 0,85 lagging. Answer the questions that follow.

Given:

$$\begin{aligned} P &= 30 \text{ kW} \\ V_L &= 400 \text{ V} \\ \text{pf} &= 0,85 \end{aligned}$$

Calculate the:

- 4.4.1 Apparent power (3)
- 4.4.2 Phase angle (3)
- 4.4.3 Reactive power (3)
- 4.4.4 Line current after the power factor was improved to 0,95 (3)
- 4.5 Prove, by means of a calculation, with reference to QUESTION 4.4 above, that power factor correction decreases the current drawn from the supply. Motivate your answer. (4)
- 4.6 Explain why the addition of capacitors in parallel with the load (power factor correction) reduces the current drawn from the supply. (3)



4.7 FIGURE 4.7 below shows the diagram of a three-phase supply, a three-phase load and two wattmeters. Answer the questions that follow.

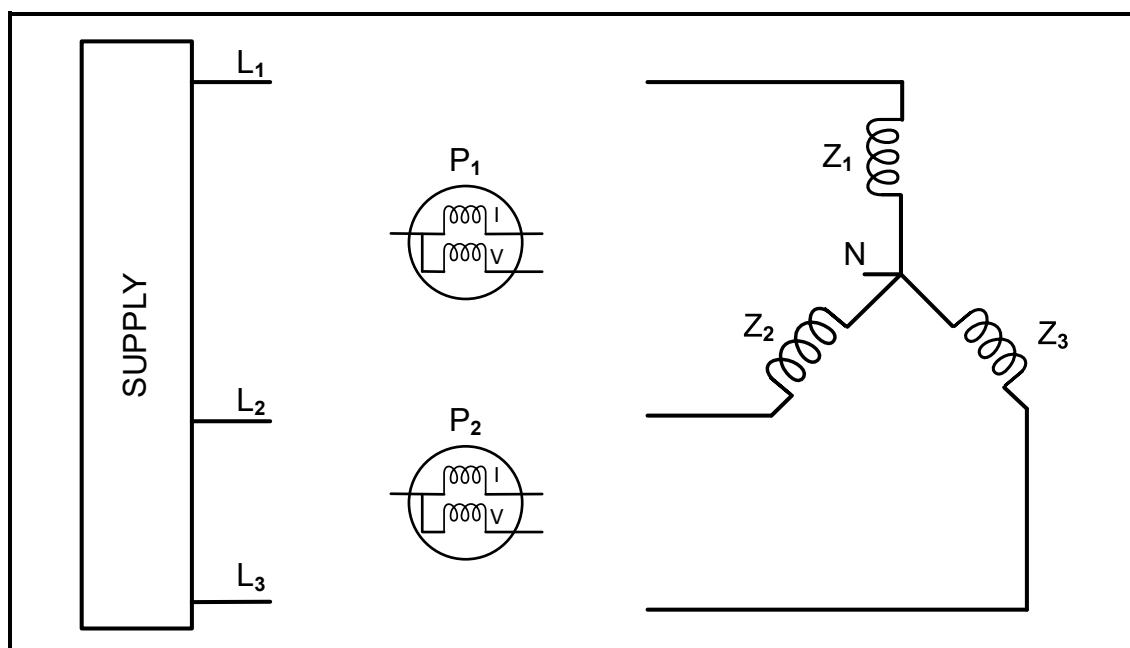

FIGURE 4.7: POWER MEASUREMENT IN A THREE-PHASE SYSTEM

4.7.1 Name ONE quantity, other than power, that can be determined by using the two-wattmeter method. (1)

4.7.2 Give TWO reasons why the two-wattmeter method is preferred over the three-wattmeter method. (2)

4.7.3 Redraw FIGURE 4.7 above and complete the drawing in your ANSWER BOOK to indicate how TWO wattmeters are connected to measure the total power. (6)

4.8 Name ONE method, other than capacitors, used to improve the power factor of a system. (1)
[35]



QUESTION 5: THREE-PHASE TRANSFORMERS

- 5.1 Name the principle on which transformers operate to transfer energy from the primary to the secondary windings. (1)
- 5.2 State the purpose of constructing a transformer core with laminated plates. (1)
- 5.3 Explain why an iron core is needed in the construction of a transformer. (2)
- 5.4 FIGURE 5.4 below shows the schematic diagram of a 200 kW delta-connected load, with a power factor of 0,8, connected to a delta-star transformer. The primary and the secondary line voltages of the transformer are 6 kV and 400 V respectively. Assume that the transformer is 100% efficient.

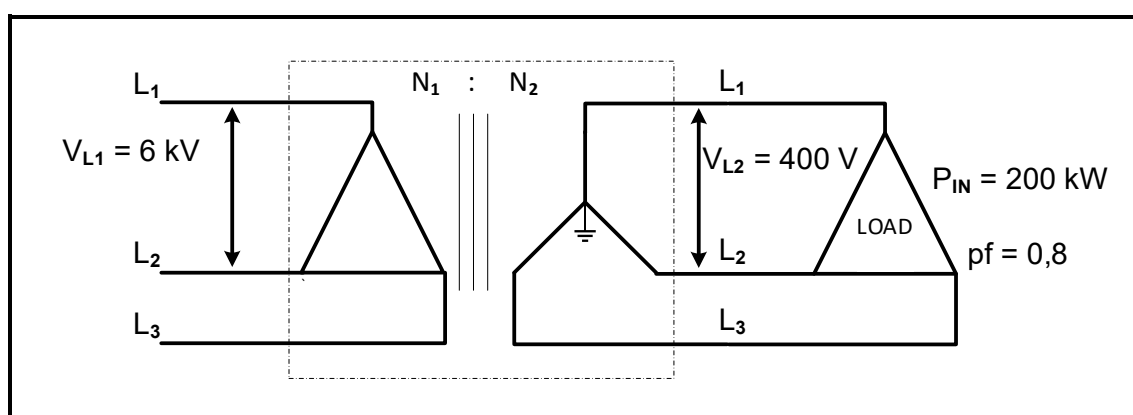
**FIGURE 5.4: DELTA-STAR TRANSFORMER WITH DELTA LOAD**

Given:

$$\begin{aligned}
 P_{IN} &= 200 \text{ kW} \\
 V_{L1} &= 6 \text{ kV} \\
 V_{L2} &= 400 \text{ V} \\
 \text{pf} &= 0,8 \\
 \eta &= 100\%
 \end{aligned}$$

Calculate the following:

- 5.4.1 Secondary line current (3)
- 5.4.2 Apparent power (3)
- 5.4.3 Primary line current (3)
- 5.4.4 Primary phase current (3)
- 5.4.5 Turns ratio of the transformer (3)



5.5 Refer to FIGURE 5.5 below and answer the questions that follow.

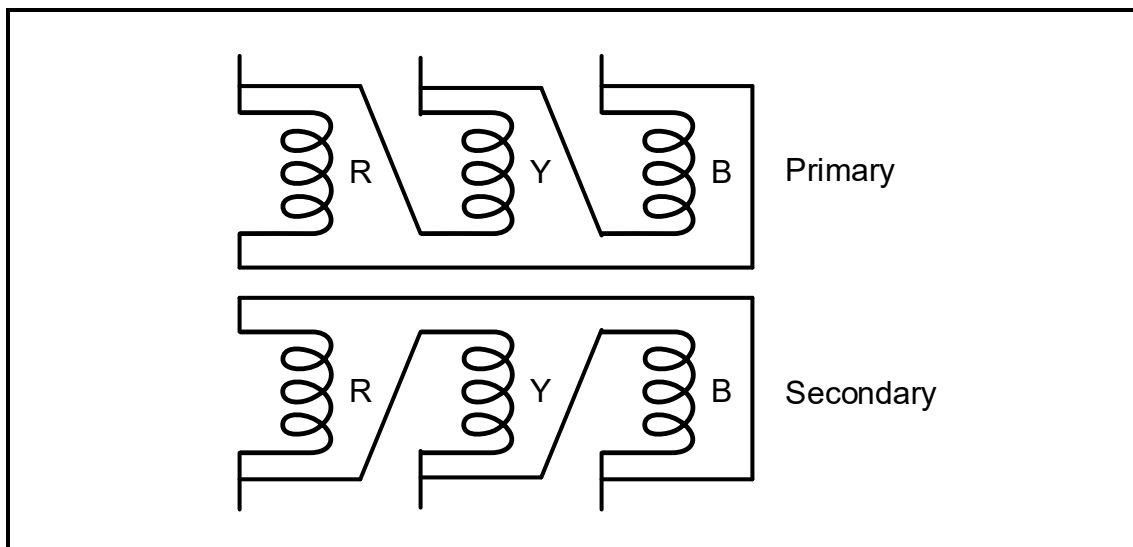

FIGURE 5.5: SINGLE-PHASE TRANSFORMERS

5.5.1 Name the configuration in which the three single-phase transformers are connected in FIGURE 5.5 above. (1)

5.5.2 State whether the primary or secondary windings are thicker if the transformer in FIGURE 5.5 above is a step-down transformer. Motivate why. (2)

5.5.3 Explain why the windings in the three single-phase transformers must be connected in the correct phasing sequence on both primary and secondary sides. (2)

5.6 Explain the term *step-up* with reference to transformers. (2)



5.7 FIGURE 5.7 below shows a line diagram of the protection devices typically used in a substation for the transformer to operate safely. Answer the questions that follow.

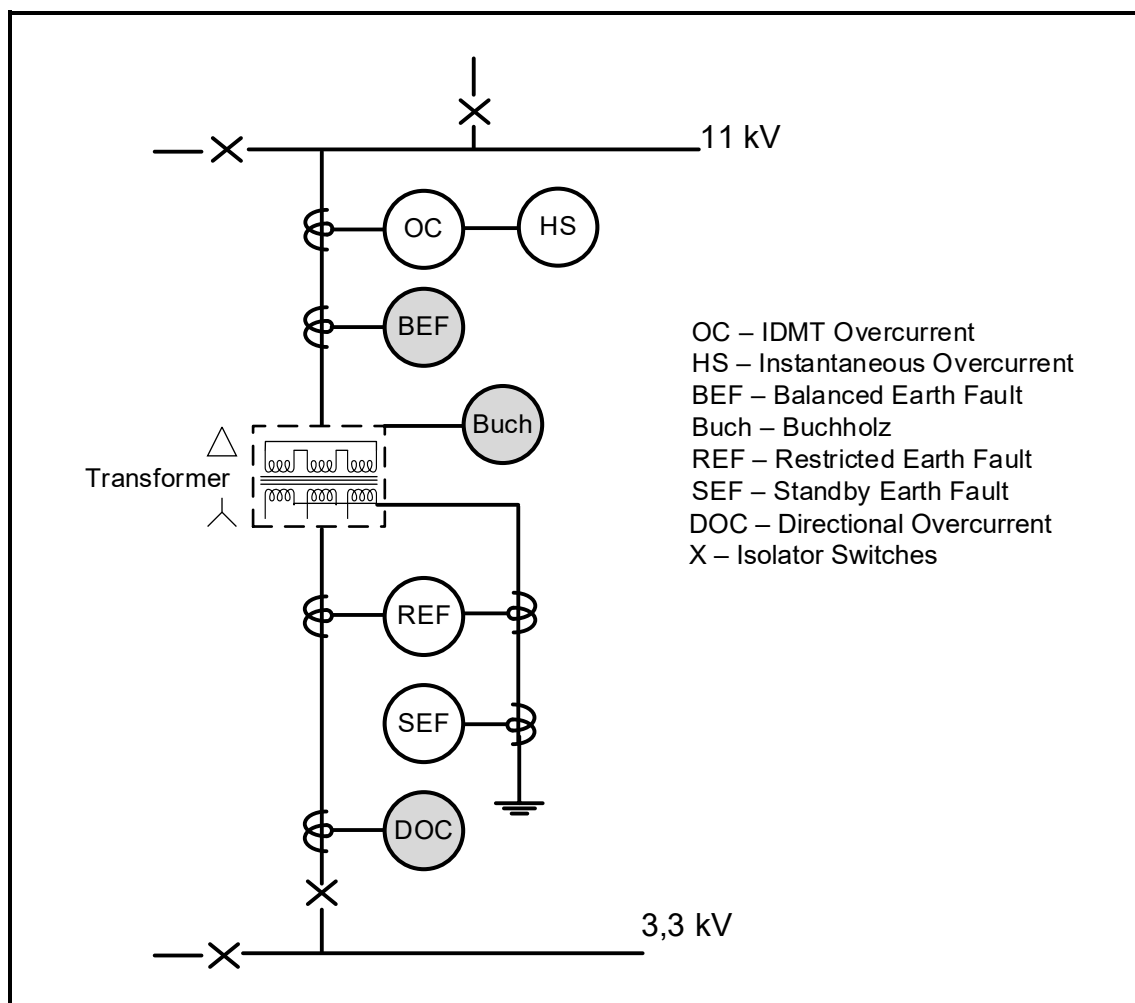

FIGURE 5.7: PROTECTION OF A TRANSFORMER IN A SUBSTATION

- 5.7.1 Name the protection device abbreviated as *DOC*. (1)
- 5.7.2 State the purpose of a Buchholz relay. (1)
- 5.7.3 Explain how the BEF (Balanced Earth Fault) relay protects the transformer. (2)

[30]



QUESTION 6: THREE-PHASE MOTORS AND STARTERS

6.1 FIGURE 6.1 below shows an exploded view of a three-phase motor. Answer the questions that follow.

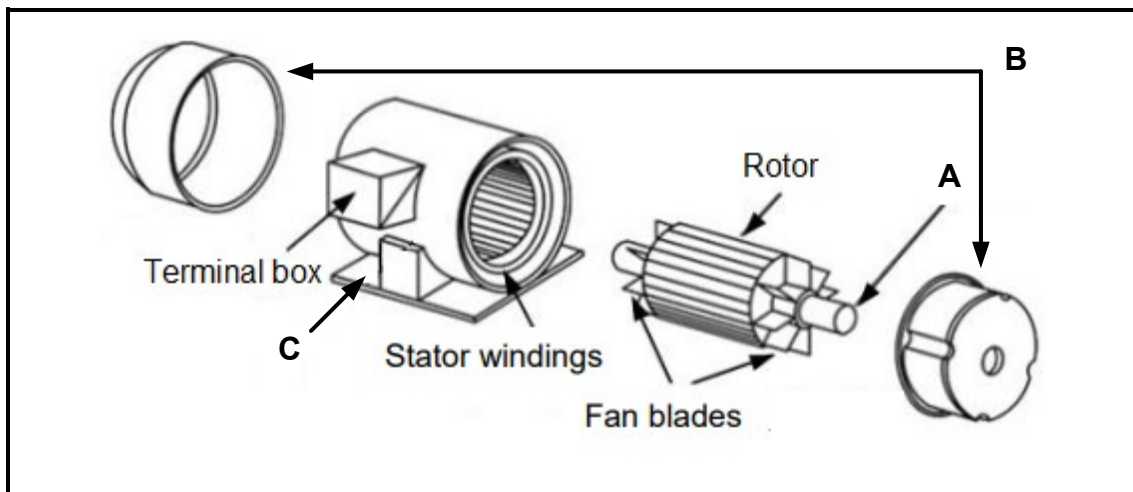

FIGURE 6.1: EXPLODED VIEW OF A THREE-PHASE MOTOR

- 6.1.1 Name **A**, **B** and **C**. (3)
- 6.1.2 Explain the purpose of the fan blades on the rotor. (1)
- 6.1.3 State TWO mechanical inspections that must be carried out on an electric motor regularly. (2)
- 6.1.4 FIGURE 6.1.4 below shows the terminal box and table with readings from three electrical tests carried out on a three-phase motor. State whether the readings are acceptable or not and motivate your answer in EACH of the following tests:

Test A	
U ₁ to U ₂	604 Ω
V ₁ to V ₂	594 Ω
W ₁ to W ₂	600 Ω
Test B	
U ₁ to W ₁	154 MΩ
Test C	
V ₁ to Earth	0,09 MΩ

TABLE 6.1.4 **TERMINAL BOX**

FIGURE 6.1.4: TERMINAL BOX AND READINGS OF A THREE-PHASE MOTOR TEST

- (a) Test **A** (2)
- (b) Test **B** (2)
- (c) Test **C** (2)



- 6.2 A three-phase delta-connected motor has a total of 18 poles and is connected to a 400 V/50 Hz supply. The input power to the motor is 12 kW with a lagging power factor of 0,9. The total losses on the motor is 500 W.

Given:

V_L	= 400 V
p	= 3
f	= 50 Hz
pf	= 0,9
losses	= 500 W
P_{IN}	= 12 kW

Calculate the:

- 6.2.1 Synchronous speed of the motor (3)
- 6.2.2 Rotor speed if there is 5% slip (3)
- 6.2.3 Efficiency of the motor (3)
- 6.2.4 Output power of the motor (3)
- 6.2.5 Line current drawn by the motor (3)



6.3 FIGURE 6.3 below shows the control circuit of an automatic star-delta motor starter with a timer. The timer is set to 3 seconds. Answer the questions that follow.

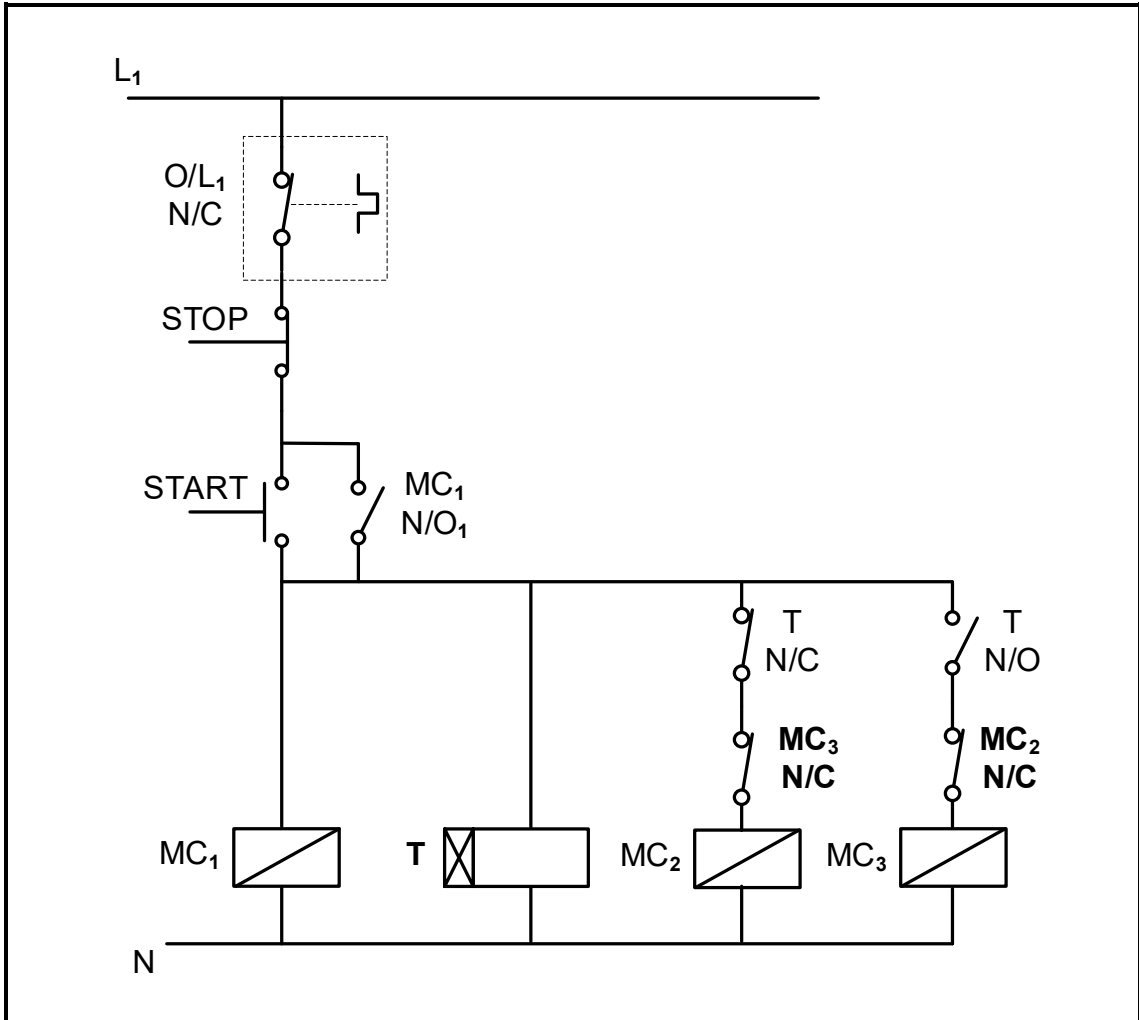

FIGURE 6.3: AUTOMATIC STAR-DELTA STARTER

- 6.3.1 State whether timer **T** is an ON-delay or an OFF-delay timer. (1)
- 6.3.2 Name the function of contacts **MC₃N/C** and **MC₂N/O**. (1)
- 6.3.3 State which contactor is responsible for connecting the motor in star. Motivate your answer. (2)
- 6.3.4 Explain the operation of the circuit from 3 seconds after the start button has been pressed. (4)

[35]



QUESTION 7: PROGRAMMABLE LOGIC CONTROLLERS (PLCs)

- 7.1 Name ONE advantage of soft-wired systems as used on PLCs. (1)
- 7.2 Explain the term *input scan* with reference to the programmed scan cycle of a PLC. (2)
- 7.3 Explain why a PLC system is safer than a hardwired system when a fault condition occurs. (2)
- 7.4 Describe the following with reference to PLCs:
- 7.4.1 Central processing unit (2)
 - 7.4.2 Soft-wired systems (2)
 - 7.4.3 PLC software (2)
- 7.5 Differentiate between an *analogue signal* and a *digital signal*. (2)
- 7.6 With reference to sensors:
- 7.6.1 Explain the term *sensor*. (2)
 - 7.6.2 Name TWO types of sensors other than a proximity sensor. (2)
 - 7.6.3 State TWO uses of a proximity sensor. (2)



7.7 Refer to FIGURE 7.7(A) below. Redraw and complete the PLC ladder logic diagram in FIGURE 7.7(B) in your ANSWER BOOK for it to execute the same function as the circuit in FIGURE 7.7(A).

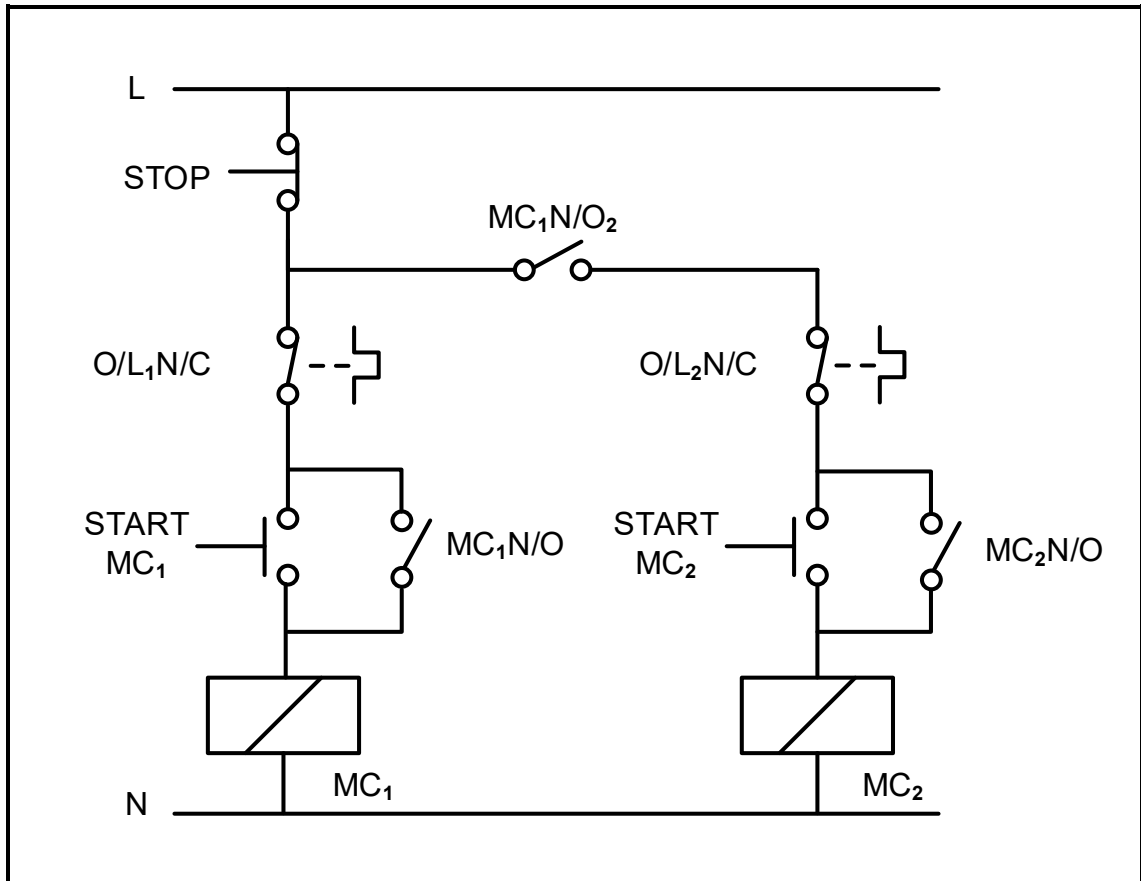

FIGURE 7.7(A): CONTROL CIRCUIT OF A MANUAL SEQUENCE STARTER

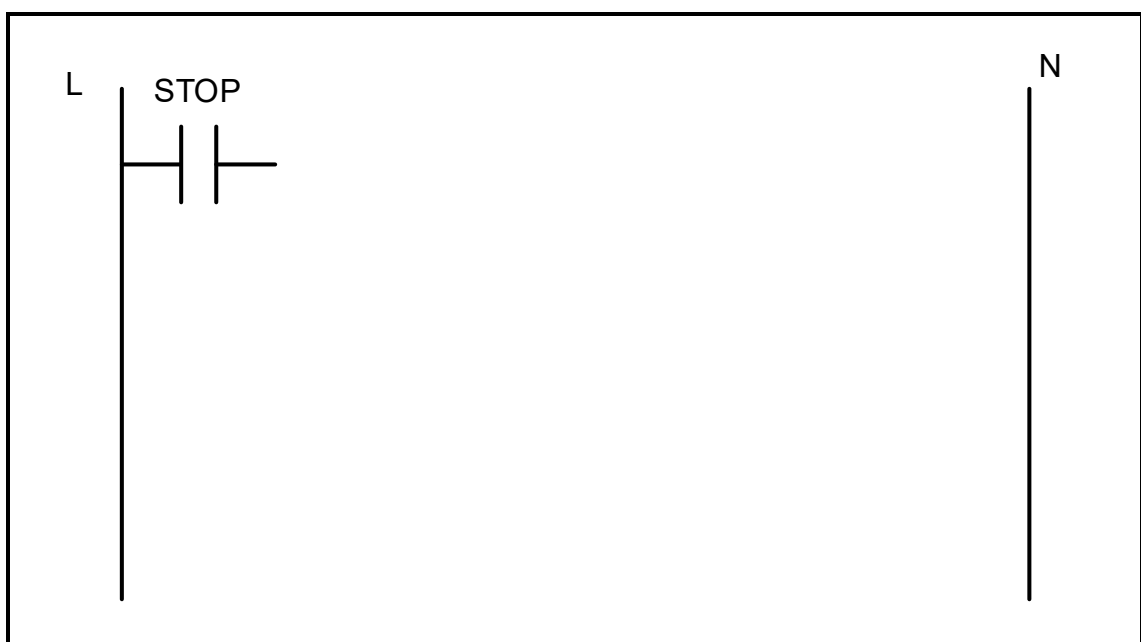

FIGURE 7.7(B): PARTIAL LADDER DIAGRAM

(9)



7.8 Explain how regenerative energy is dissipated by the following components in a motor that is controlled by a VSD:

7.8.1 DC capacitors (1)

7.8.2 Braking resistor (2)

7.9 Refer to FIGURE 7.9 below and answer the questions that follow.

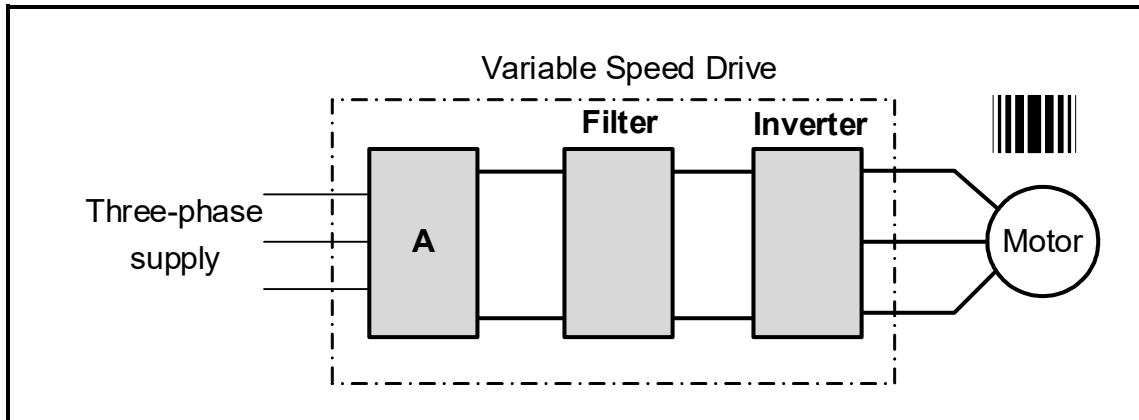

FIGURE 7.9: BLOCK DIAGRAM OF VSD

7.9.1 Label block **A**. (1)

7.9.2 Name the main component used in the filter circuit. (1)

7.9.3 Describe the operation of the inverter. (5)

7.9.4 State TWO advantages of using VSDs as a motor controller. (2)

[40]

TOTAL: 200



FORMULA SHEET	
RLC CIRCUITS	THREE-PHASE AC GENERATION
$P = V I \cos \theta$ $X_L = 2\pi fL$ $X_C = \frac{1}{2\pi fC}$ $f_r = \frac{1}{2\pi\sqrt{LC}}$ OR $f_r = \frac{f_1 + f_2}{2}$ $BW = \frac{f_r}{Q}$ OR $BW = f_2 - f_1$ SERIES $V_R = IR$ $V_L = IX_L$ $V_C = IX_C$ $I_T = \frac{V_T}{Z}$ OR $I_T = I_R = I_C = I_L$ $Z = \sqrt{R^2 + (X_L - X_C)^2}$ $V_T = \sqrt{V_R^2 + (V_L - V_C)^2}$ OR $V_T = IZ$ $\cos \theta = \frac{R}{Z}$ OR $\cos \theta = \frac{V_R}{V_T}$ OR $\tan \theta = \frac{V_L - V_C}{V_R}$ $Q = \frac{X_L}{R} = \frac{X_C}{R} = \frac{V_L}{V_T} = \frac{V_C}{V_T} = \frac{1}{R} \sqrt{\frac{L}{C}}$ PARALLEL $V_T = V_R = V_C = V_L$ $I_R = \frac{V_T}{R}$ $I_C = \frac{V_T}{X_C}$ $I_L = \frac{V_T}{X_L}$ $I_T = \sqrt{I_R^2 + (I_C - I_L)^2}$ $Z = \frac{V_T}{I_T}$ $\cos \theta = \frac{I_R}{I_T}$ $Q = \frac{R}{X_L} = \frac{R}{X_C}$	STAR $V_L = \sqrt{3} V_{PH}$ $V_{PH} = I_{PH} Z_{PH}$ $I_L = I_{PH}$ DELTA $V_L = V_{PH}$ $V_{PH} = I_{PH} Z_{PH}$ $I_L = \sqrt{3} I_{PH}$ POWER $S(P_{APP}) = \sqrt{3} V_L I_L$ $Q(P_r) = \sqrt{3} V_L I_L \sin \theta$ $P = \sqrt{3} V_L I_L \cos \theta$ $\cos \theta = \frac{P}{S}$ $P_T = P_1 + P_2$ $Q_T = Q_1 + Q_2$ $S = \sqrt{(P_T)^2 + (Q_T)^2}$ EFFICIENCY $\eta = \frac{P_{OUT}}{P_{IN}} \times 100$ TWO-WATTMETER METHOD $P_T = P_1 + P_2$ $\tan \theta = \sqrt{3} \left(\frac{P_1 - P_2}{P_1 + P_2} \right)$ THREE-WATTMETER METHOD $P_T = P_1 + P_2 + P_3$



THREE-PHASE TRANSFORMERS	THREE-PHASE MOTORS AND STARTERS
<p>STAR</p> $V_L = \sqrt{3} V_{PH}$ $I_L = I_{PH}$ <p>DELTA</p> $V_L = V_{PH}$ $I_L = \sqrt{3} I_{PH}$ <p>POWER</p> $S(P_{APP}) = \sqrt{3} V_L I_L$ $Q(P_r) = \sqrt{3} V_L I_L \sin \theta$ $P = \sqrt{3} V_L I_L \cos \theta$ $\cos \theta = pf = \frac{P}{S}$ $\frac{V_{PH(1)}}{V_{PH(2)}} = \frac{N_1}{N_2} = \frac{I_{PH(2)}}{I_{PH(1)}}$ <p>Turns ratio: $TR = \frac{N_1}{N_2}$</p> $\eta = \frac{P_{OUT}}{P_{OUT} + \text{losses}} \times 100$	<p>STAR</p> $V_L = \sqrt{3} V_{PH}$ $I_L = I_{PH}$ <p>DELTA</p> $V_L = V_{PH}$ $I_L = \sqrt{3} I_{PH}$ <p>POWER</p> $S(P_{APP}) = \sqrt{3} V_L I_L$ $Q(P_r) = \sqrt{3} V_L I_L \sin \theta$ $P = \sqrt{3} V_L I_L \cos \theta$ $P = \sqrt{3} V_L I_L \cos \theta \eta$ $\cos \theta = pf = \frac{P}{S}$ $P_T = P_1 + P_2 \text{ (real power)}$ $Q_T = Q_1 + Q_2 \text{ (reactive power)}$ <p>EFFICIENCY</p> $\eta = \frac{P_{IN} - \text{losses}}{P_{IN}} \times 100$ $\eta = \frac{P_{OUT}}{P_{IN}} \times 100$ $n_s = \frac{60 f}{p}$ $\text{Per Unit Slip} = \frac{n_s - n_r}{n_s}$ $\% \text{ slip} = \frac{n_s - n_r}{n_s} \times 100$ $n_r = n_s(1 - \% \text{ slip})$ $\text{Slip} = n_s - n_r$

