

Confidential



basic education

Department:
Basic Education
REPUBLIC OF SOUTH AFRICA

SENIOR CERTIFICATE EXAMINATIONS/ NATIONAL SENIOR CERTIFICATE EXAMINATIONS

ELECTRICAL TECHNOLOGY: ELECTRONICS

MAY/JUNE 2025

MARKS: 200

TIME: 3 hours

**This question paper consists of 26 pages, including a 1-page formula sheet
and a 5-page answer sheet.**



INSTRUCTIONS AND INFORMATION

1. This question paper consists of SIX questions.
2. Answer ALL the questions.
3. Answer the following questions on the attached ANSWER SHEETS:

QUESTIONS 4.6.2
QUESTIONS 5.3.3, 5.4 and 5.5.2
QUESTIONS 6.5.4 and 6.7.4
4. Write your centre number and examination number on every ANSWER SHEET and hand them in with your ANSWER BOOK, whether you have used them or not.
5. Sketches and diagrams must be large, neat and FULLY LABELLED.
6. Show ALL calculations and round off answers correctly to TWO decimal places.
7. Number the answers correctly according to the numbering system used in this question paper.
8. You may use a non-programmable calculator.
9. Calculations must include:
 - 9.1 Formulae and manipulations where needed
 - 9.2 Correct replacement of values
 - 9.3 Correct answer and relevant units where applicable
10. A formula sheet is attached at the end of this question paper.
11. Write neatly and legibly. ∞



QUESTION 1: MULTIPLE-CHOICE QUESTIONS

Various options are provided as possible answers to the following questions. Choose the answer and write only the letter (A–D) next to the question numbers (1.1 to 1.15) in the ANSWER BOOK, e.g. 1.16 D.

- 1.1 A critical incident is an event where ...
- A a learner is injured without requiring first aid.
 - B pain is caused due to a soldering iron burn.
 - C a learner is injured and external emergency assistance is needed.
 - D the skin turns red when rinsing etching acid with water after a minor spillage. (1)
- 1.2 In an RLC series circuit, with the supply frequency far below the resonant frequency, the nature of the circuit's reactance is ...
- A more inductive.
 - B more capacitive.
 - C equal to the impedance.
 - D equal to the resistance. (1)
- 1.3 In an RLC series resonant circuit the ...
- A supply voltage is equal to the voltage across the inductor plus the voltage across the capacitor.
 - B voltage across the inductor and the capacitor are equal in magnitude and opposite in phase, resulting in their sum being zero.
 - C supply voltage is equal to the voltage across the resistor and inductor.
 - D voltage across the inductor and capacitor are both zero. (1)
- 1.4 The impedance of an RLC parallel resonant circuit is ...
- A at its maximum value.
 - B at its minimum value.
 - C equal to the difference between X_L and X_C .
 - D purely reactive. (1)
- 1.5 A ... is a voltage-controlled device which does NOT have amplifying properties.
- A bipolar junction transistor
 - B unijunction transistor
 - C field-effect transistor
 - D metal-oxide field-effect transistor (1)
- 1.6 The ... of a unijunction transistor (UJT) together with the supply voltage determines the voltage at which the device will trigger on.
- A offset voltage
 - B intrinsic stand-off ratio
 - C valley point
 - D pinch-off voltage (1)



- 1.7 When a signal is applied to the inverting input terminal of an op amp, the ... provide a phase shift.
- A band pass filters
 - B electrostatic charges
 - C internal amplifier circuits
 - D temperature measurements
- (1)
- 1.8 With reference to the supply voltage of a 555 IC and a 741 op amp the ...
- A 741 op amp uses a dual voltage supply to amplify only negative signals.
 - B 555 IC uses a dual voltage supply to amplify both positive and negative signals.
 - C 555 IC uses the dual voltage supply to amplify only positive signals.
 - D 741 op amp uses a dual voltage supply to amplify both positive and negative signals.
- (1)
- 1.9 In a 555 timer connected as an astable multivibrator, the ... determine(s) the frequency of the output waveform.
- A external trigger pulse width
 - B duty cycle set by the control voltage
 - C values of the external resistors and capacitor
 - D supply voltage to the 555 timers
- (1)
- 1.10 The purpose of the feedback resistor in an inverting summing amplifier is to ...
- A set the input impedance of the amplifier.
 - B ensure that the output voltage is zero when all input voltages are zero.
 - C increase the output impedance.
 - D determine the gain of the amplifier for the input signals fed to it.
- (1)
- 1.11 In a Schmitt trigger circuit, the term 'hysteresis' refers to the ...
- A delay between the input and output signals.
 - B amplification factor of the op amp.
 - C time lag between cause and effect.
 - D frequency response of the circuit.
- (1)
- 1.12 Introducing an op amp to the passive RC differentiator circuit ...
- A produces an output voltage proportional to the integral of the input voltage.
 - B improves input and output impedances.
 - C provides 100% feedback.
 - D filters out high-frequency noise.
- (1)



- 1.13 A class B push-pull bipolar junction transistor amplifier uses ...
- A two NPN transistors.
 - B two PNP transistors.
 - C one PNP and one NPN transistor.
 - D one NPN transistor. (1)
- 1.14 A class B amplifier is biased with the quiescent point ... of the load line.
- A at the cut-off region
 - B at the saturation
 - C at the midpoint
 - D above the midpoint (1)
- 1.15 The power dissipation of a class C amplifier is normally ...
- A very low.
 - B very high.
 - C the same as a class B.
 - D the same as a class A. (1)
- [15]**

QUESTION 2: OCCUPATIONAL HEALTH AND SAFETY

- 2.1 Define *health and safety equipment*. (2)
- 2.2 State TWO unsafe acts, regarding safety equipment, that are forbidden in an electrical technology workshop.. (2)
- 2.3 State the purpose of the Occupational Health and Safety Act, 1993 (Act 85 of 1993). (2)
- 2.4 Explain why it is important for employers to inform employees about health and safety at the workplace. (2)
- 2.5 Briefly explain why discipline is considered an important work ethic with reference to the electrical technology workshop. (2)
- [10]**



QUESTION 3: RLC CIRCUITS

- 3.1 Explain the term *reactance* with reference to a pure inductive circuit. (2)
- 3.2 Refer to the circuit in FIGURE 3.2 below and answer the questions that follow.

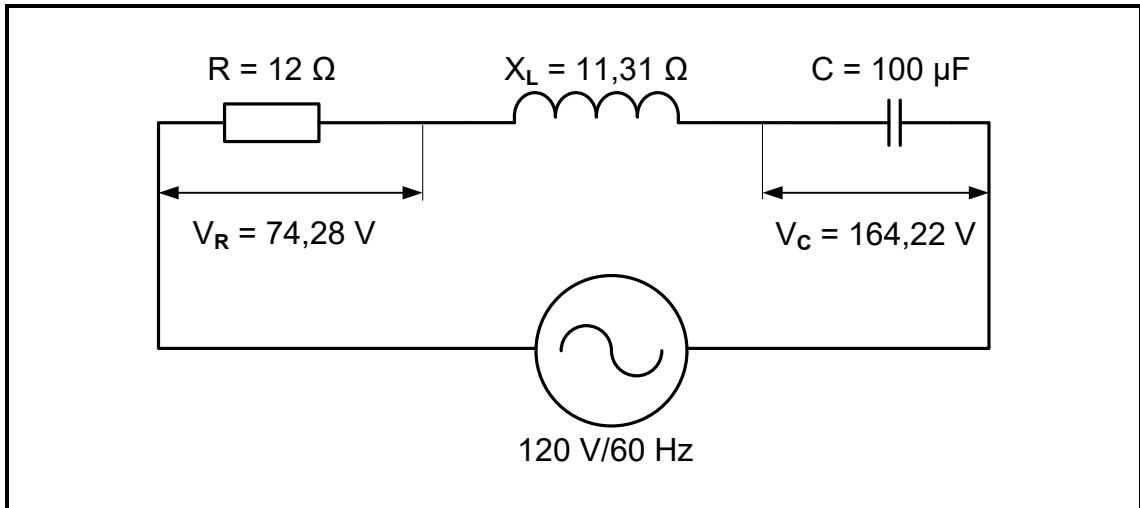

FIGURE 3.2: RLC SERIES CIRCUIT

Given:

- $V_T = 120 \text{ V}$
- $R = 12 \text{ } \Omega$
- $X_L = 11,31 \text{ } \Omega$
- $C = 100 \text{ } \mu\text{F}$
- $V_R = 74,28 \text{ V}$
- $V_C = 164,22 \text{ V}$
- $f = 60 \text{ Hz}$

Calculate the:

- 3.2.1 Capacitive reactance (3)
- 3.2.2 Total current (3)
- 3.2.3 Voltage across the inductor (3)
- 3.2.4 Capacitive value that will cause resonance (3)
- 3.3 Redraw and complete the phasor diagram in FIGURE 3.3 below. When labelling, use the relevant calculated values from the calculations above. (5)

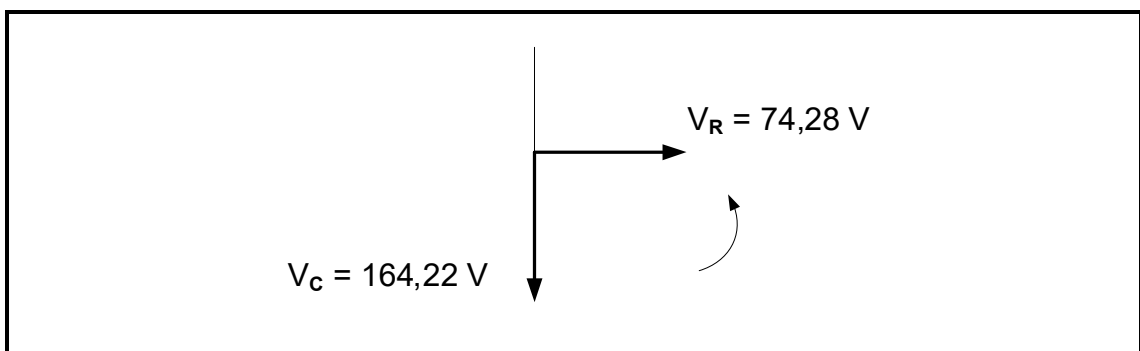

FIGURE 3.3



3.4 Refer to FIGURE 3.4 below and answer the questions that follow.

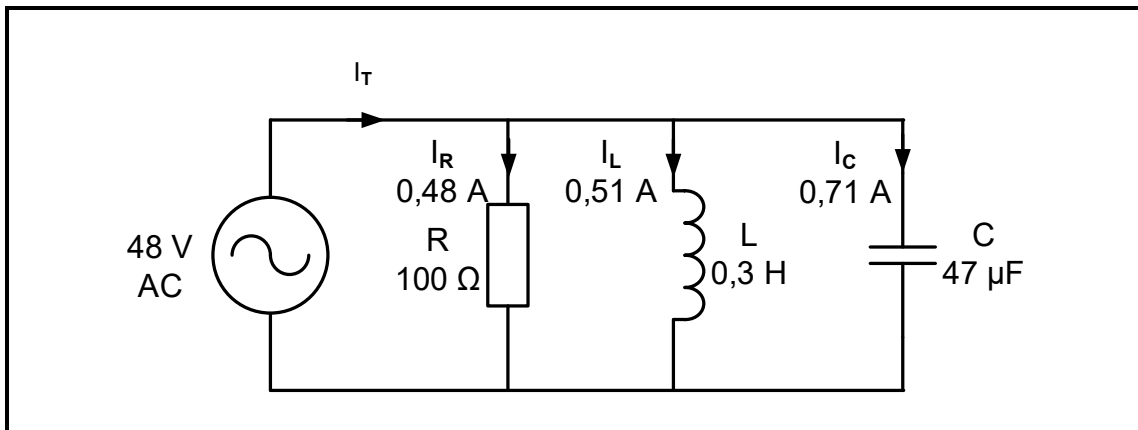

FIGURE 3.4: PARALLEL CIRCUIT

Given:

V_T	= 48 V
I_R	= 0,48 A
I_L	= 0,51 A
I_C	= 0,71 A
R	= 100 Ω
L	= 0,3 H
C	= 47 μF

Calculate the:

- 3.4.1 Total current (3)
- 3.4.2 Phase angle (3)
- 3.4.3 Inductive reactance (3)
- 3.4.4 Supply frequency of the circuit (3)



3.5 FIGURE 3.5 below shows the Q-factor characteristic curve of an RLC circuit, NOT drawn to scale. Q_1 and Q_2 indicate how a change in the L/C ratio affects the Q-factor of a resonant circuit. Answer the questions that follow.

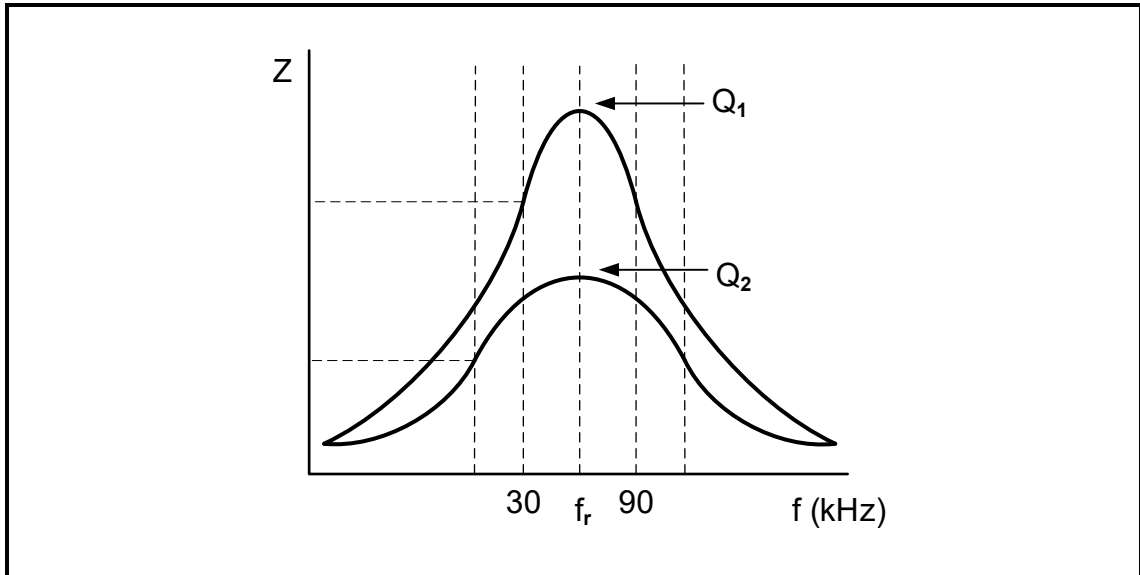

FIGURE 3.5: Q-FACTOR CHARACTERISTIC CURVE

- 3.5.1 Identify the curve with the widest bandwidth. (1)
 - 3.5.2 Calculate the resonant frequency for Q_1 . (3)
- [35]**



QUESTION 4: SEMICONDUCTOR DEVICES

- 4.1 Describe a field-effect transistor (FET) with reference to semiconductors. (2)
- 4.2 Refer to FIGURE 4.2 below and answer the questions that follow.

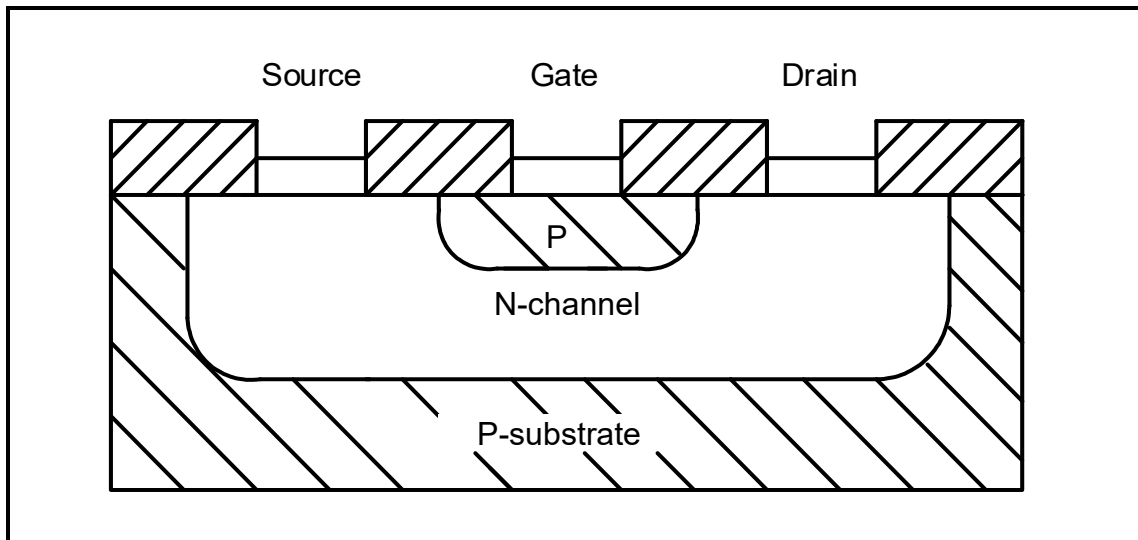
**FIGURE 4.2: CONSTRUCTION OF AN N-CHANNEL JFET**

- 4.2.1 Name the technique used for the manufacturing of the N-channel JFET in FIGURE 4.2. (1)
- 4.2.2 Describe why field-effect transistors are regarded as unipolar transistors. (3)
- 4.2.3 Discuss the operating principle of the junction field-effect transistor (JFET) when the gate voltage is increased negatively. (4)
- 4.2.4 Explain the term *pinch-off point* with reference to the operation of a junction field-effect transistor (JFET). (3)



4.3 Refer to FIGURE 4.3 below and answer the questions that follow.

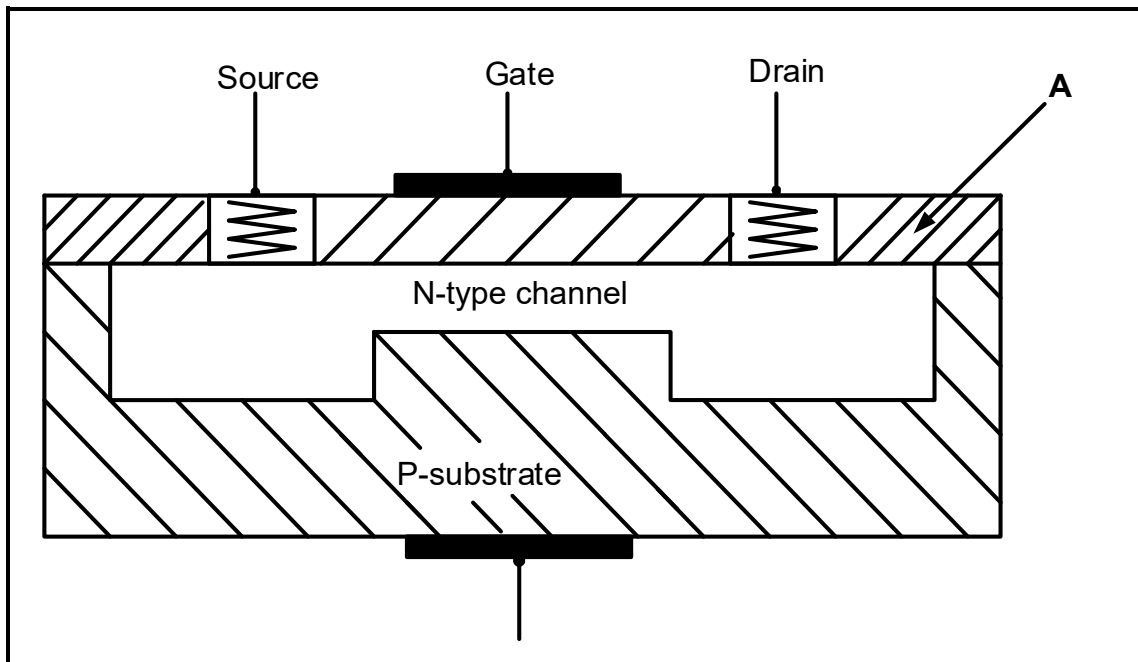

FIGURE 4.3: CONSTRUCTION OF A MOSFET

- 4.3.1 Identify the mode in which the MOSFET in FIGURE 4.3 above is operated. (1)
- 4.3.2 Name **A** in FIGURE 4.3 above. (1)
- 4.3.3 State the advantage of the MOSFET when compared to the JFET with reference to its gate. (2)
- 4.3.4 Briefly describe the operating principle of the MOSFET in FIGURE 4.3 above when a negative potential is applied to the gate. (3)



4.4 Refer to FIGURE 4.4 below and answer the questions that follow.

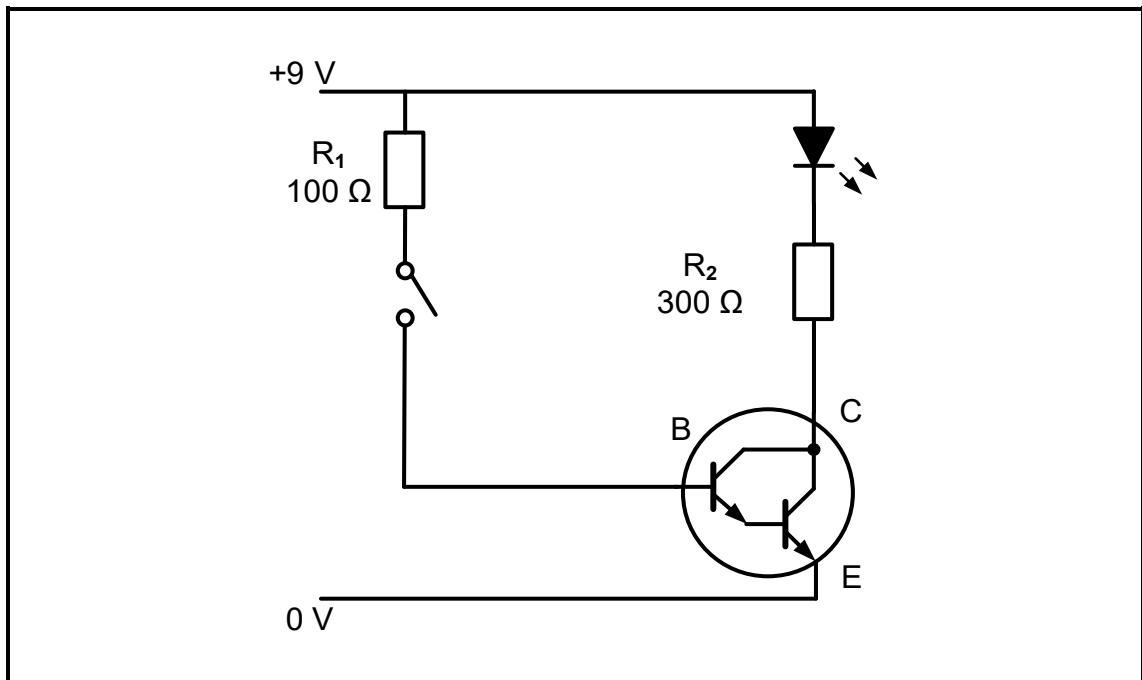

FIGURE 4.4: DARLINGTON TRANSISTOR

- 4.4.1 Name ONE application of the circuit in FIGURE 4.4 above. (1)
- 4.4.2 Name another component that can be used instead of a switch in the circuit. (1)
- 4.4.3 State the purpose of the 100 Ω resistor in FIGURE 4.4 above. (1)
- 4.4.4 Explain why a Darlington transistor is often regarded as a buffer in a circuit. (2)



4.5 Refer to FIGURE 4.5 below and answer the questions that follow.

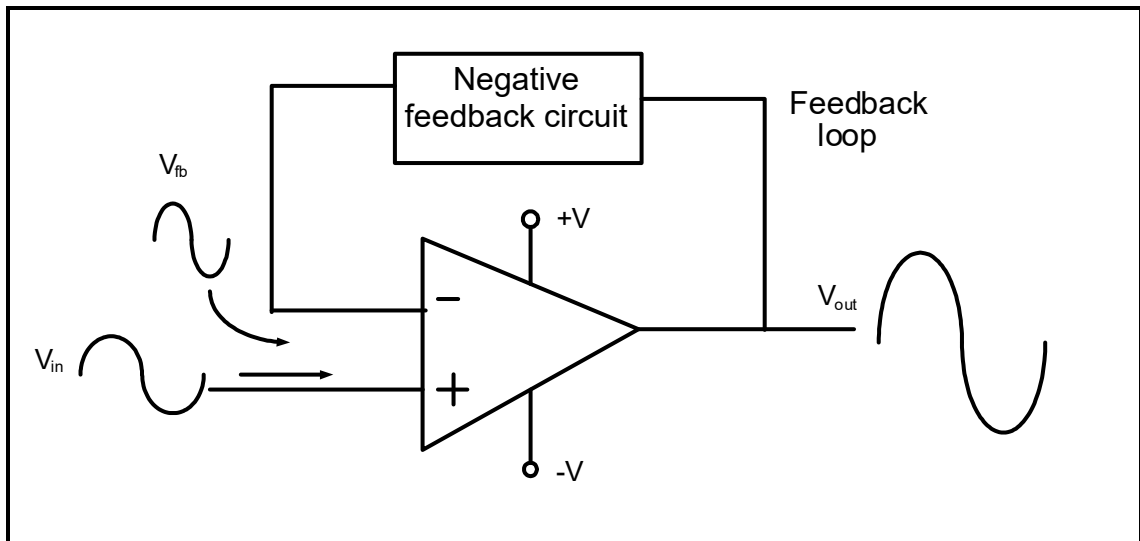

FIGURE 4.5: FEEDBACK OF OP AMP

4.5.1 State what would happen to the amplitude of the output signal when negative feedback is increased. (1)

4.5.2 Briefly describe the effect of the negative feedback circuit in FIGURE 4.5 above. (2)

4.6 Refer to FIGURE 4.6 below and answer the questions that follow.

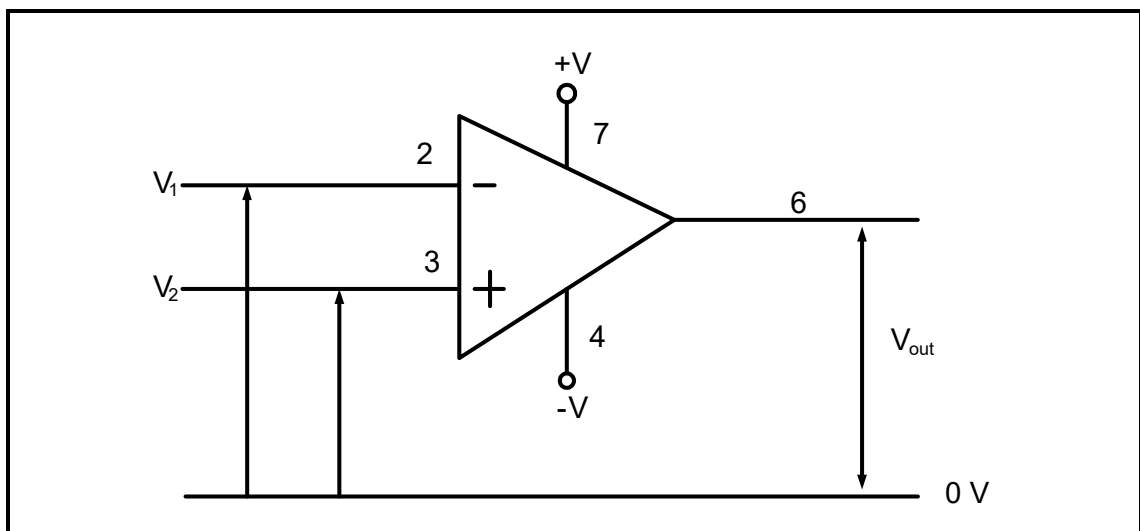

FIGURE 4.6: IDEAL OPERATIONAL AMPLIFIER

4.6.1 Explain why an ideal operational amplifier has infinite bandwidth. (1)

4.6.2 Draw the output of the op amp in FIGURE 4.6 above on the ANSWER SHEET for QUESTION 4.6.2 when the input at pin 2 and pin 3 is identical and in phase. (1)

4.6.3 Give TWO reasons why operational amplifiers are popular building blocks of analogue electronics circuits. (2)



4.7 Refer to FIGURE 4.7 below and answer the questions that follow.

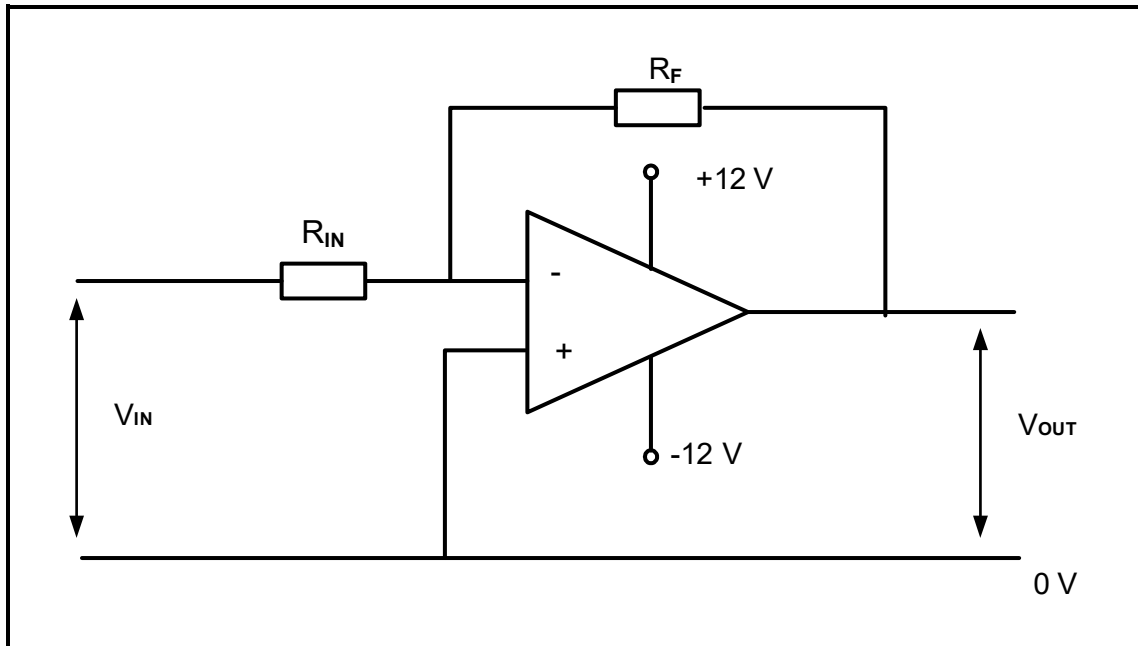

FIGURE 4.7: INVERTING OPERATIONAL AMPLIFIER

- 4.7.1 If R_F is damaged and creates an open circuit, explain what effect it would have on the output of the circuit. (1)
- 4.7.2 State the principle according to which the circuit in FIGURE 4.7 above operates to have a zero volt at the inverting input. (1)
- 4.7.3 Calculate the value of the feedback resistor if the input resistor of $15\text{ k}\Omega$ is connected to an input voltage of 1 V , producing an output voltage of -12 V . (3)



4.8 FIGURE 4.8 shows the internal layout of the 555 timer IC. Answer the questions that follow.

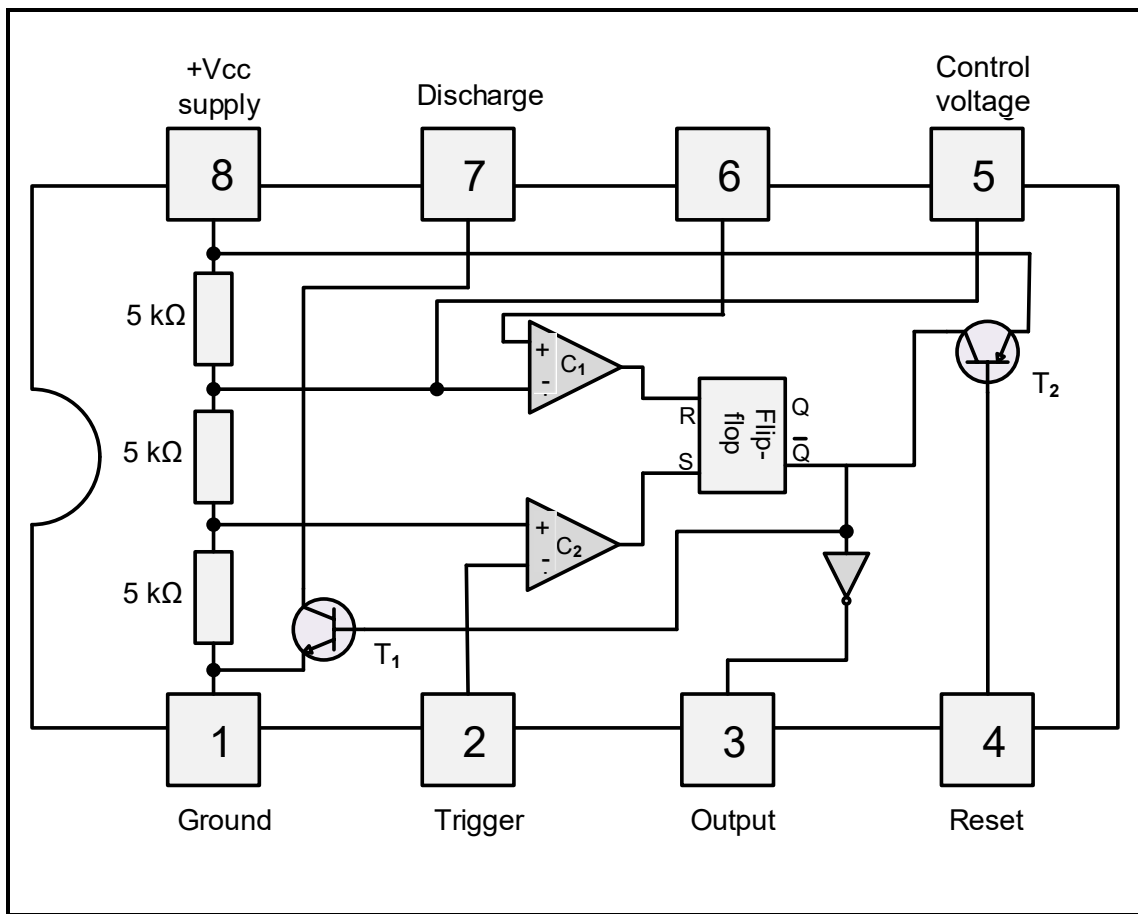

FIGURE 4.8: INTERNAL LAYOUT OF A 555 TIMER IC

- 4.8.1 State the function of the comparators' output. (1)
- 4.8.2 State the condition for which T₂ in FIGURE 4.8 above will be activated. (1)
- 4.8.3 Explain what happens when the trigger voltage goes below $\frac{1}{3}V_{cc}$. (2)
- 4.8.4 Briefly describe the functions of pin 6 with reference to the 555 IC. (2)
- 4.8.5 Name TWO industrial applications of the 555 IC. (2)

[45]



QUESTION 5: SWITCHING CIRCUITS

5.1 Explain the term *astable* with reference to multivibrator circuits. (2)

5.2 FIGURE 5.2 below shows a bistable multivibrator circuit with pushbutton switches on the input and monitored by two voltmeters on the output. Answer the questions that follow.

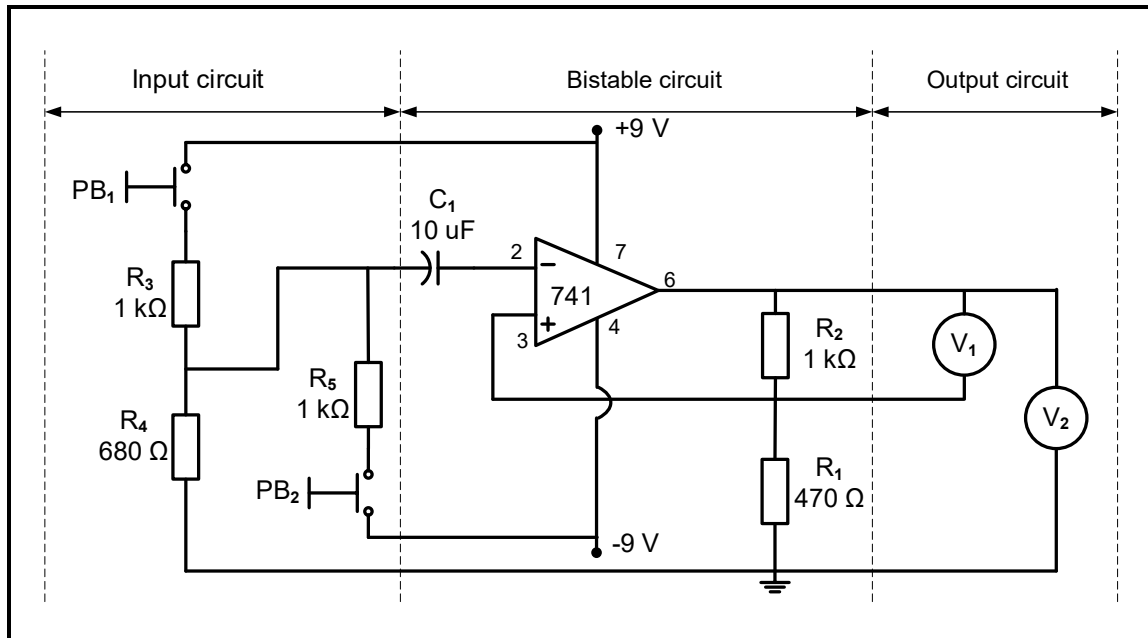

FIGURE 5.2: BISTABLE MULTIVIBRATOR

5.2.1 With reference to the input circuit, state why this is a bistable multivibrator circuit. (1)

5.2.2 State the purpose of R₁ and R₂. (2)

5.2.3 Explain the operation of the circuit in FIGURE 5.2 above when PB₁ is pressed. (4)

5.2.4 With reference to FIGURE 5.2.4 below, explain why the output did not change at trigger pulse 2. (2)

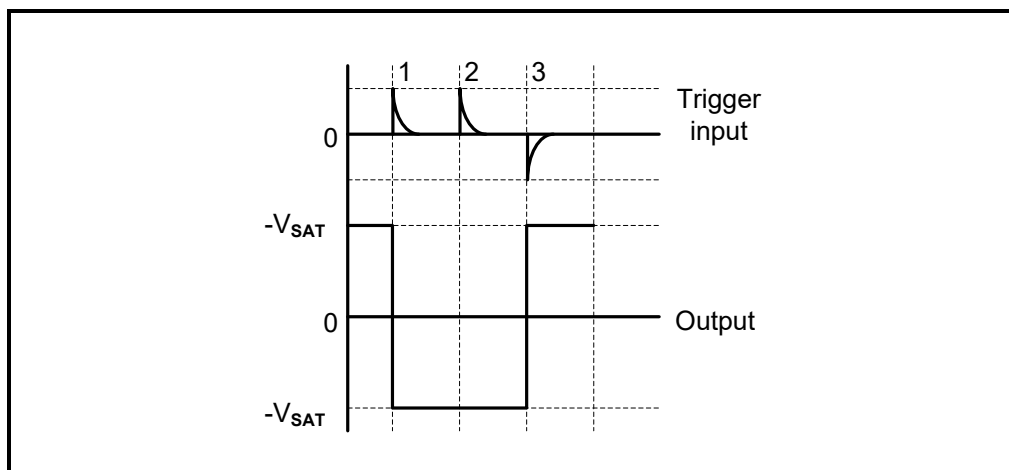

FIGURE 5.2.4: BISTABLE INPUT vs OUTPUT SIGNALS



5.3 Refer to FIGURE 5.3 below and answer the questions that follow.

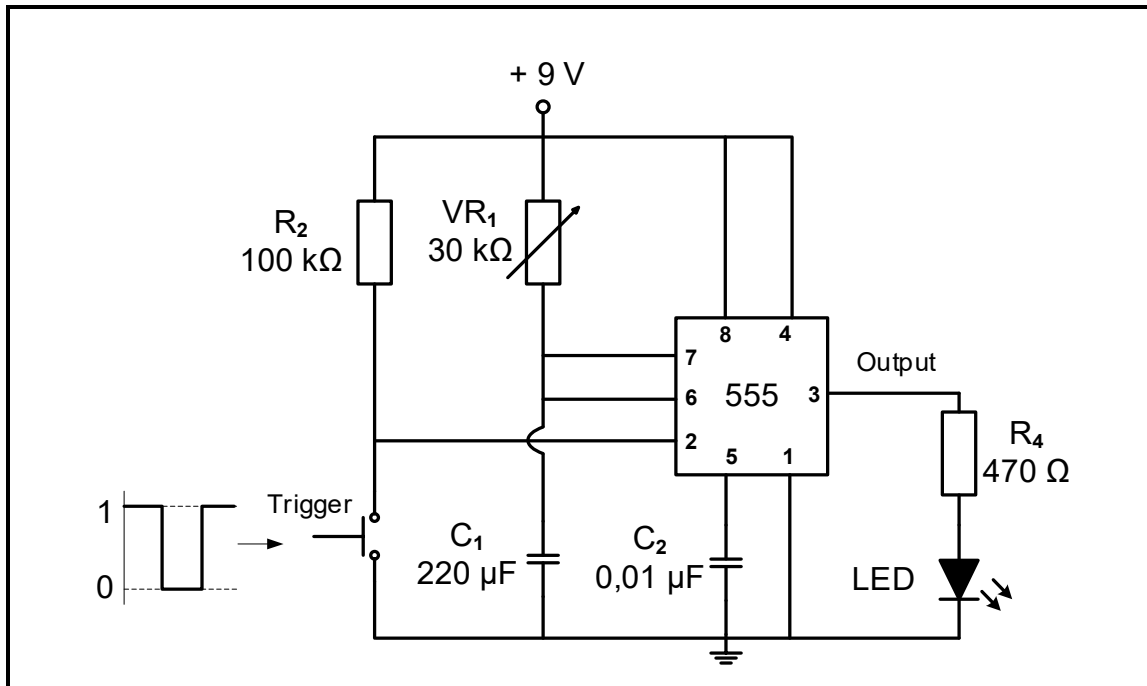

FIGURE 5.3: MONOSTABLE MULTIVIBRATOR CIRCUIT

- 5.3.1 Explain the purpose of R₂. (2)
- 5.3.2 Explain how the circuit in FIGURE 5.3 above can be improved to provide protection for pin 7 and pin 6. (2)
- 5.3.3 Draw the waveforms for the voltage across the capacitor and the correlating output on the ANSWER SHEET for QUESTION 5.3.3, when the variable resistor (VR₁) is set to 10 kΩ. (5)

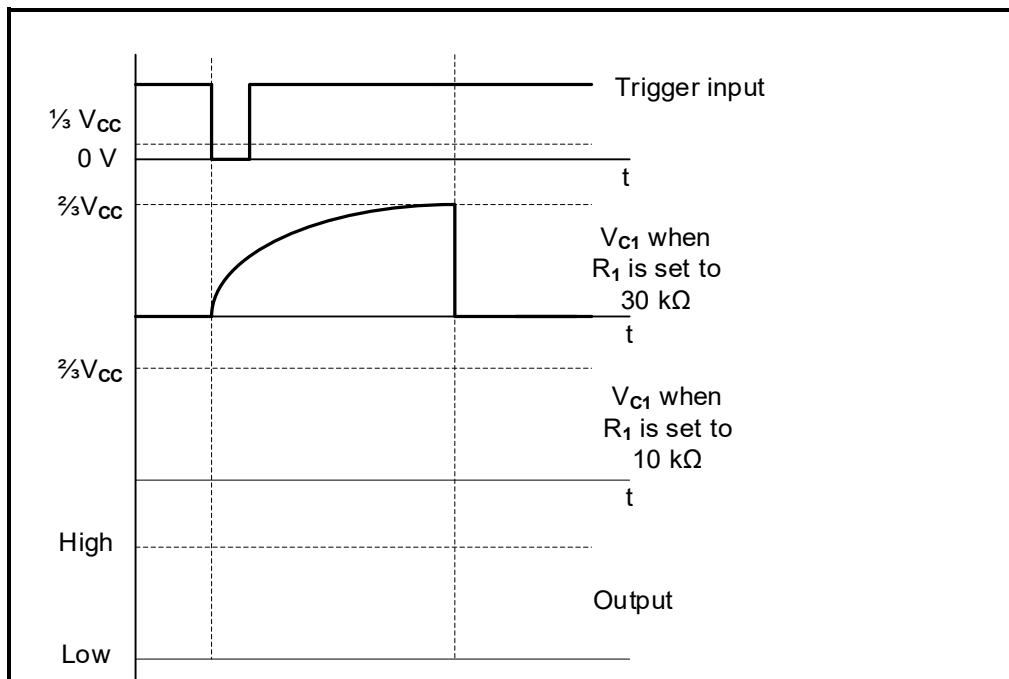

FIGURE 5.3.3

(5)



5.4 Refer to FIGURE 5.4 below and complete the drawing by using the components in TABLE 5.4 on the ANSWER SHEET for QUESTION 5.4 to create an astable multivibrator.

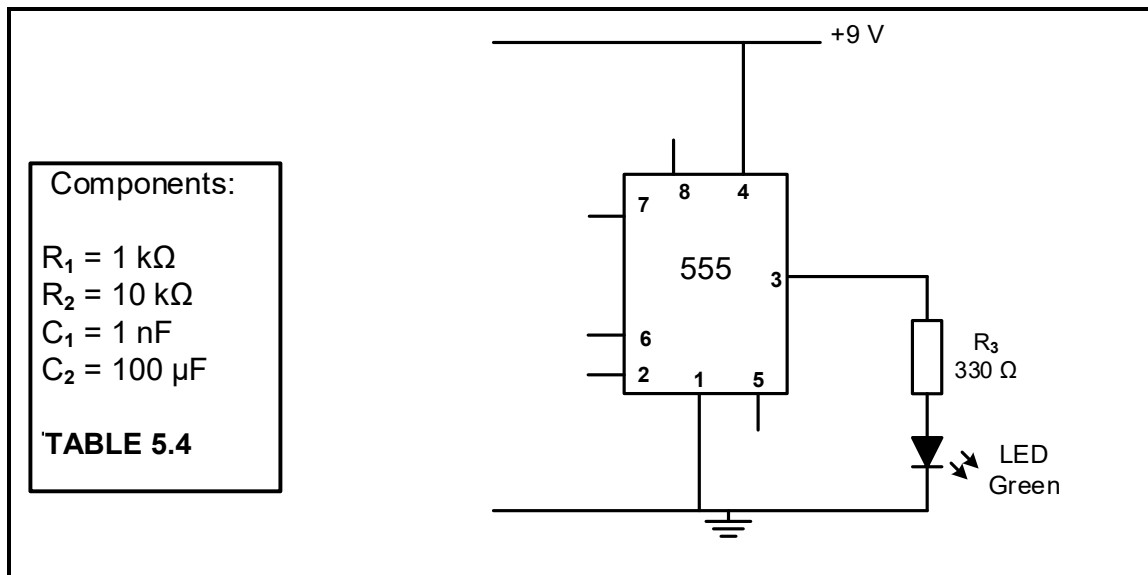

FIGURE 5.4: 555 IC PARTIAL ASTABLE CIRCUIT

(8)

5.5 FIGURE 5.5 below shows the basic circuit diagram of a Schmitt trigger. Answer the questions that follow.

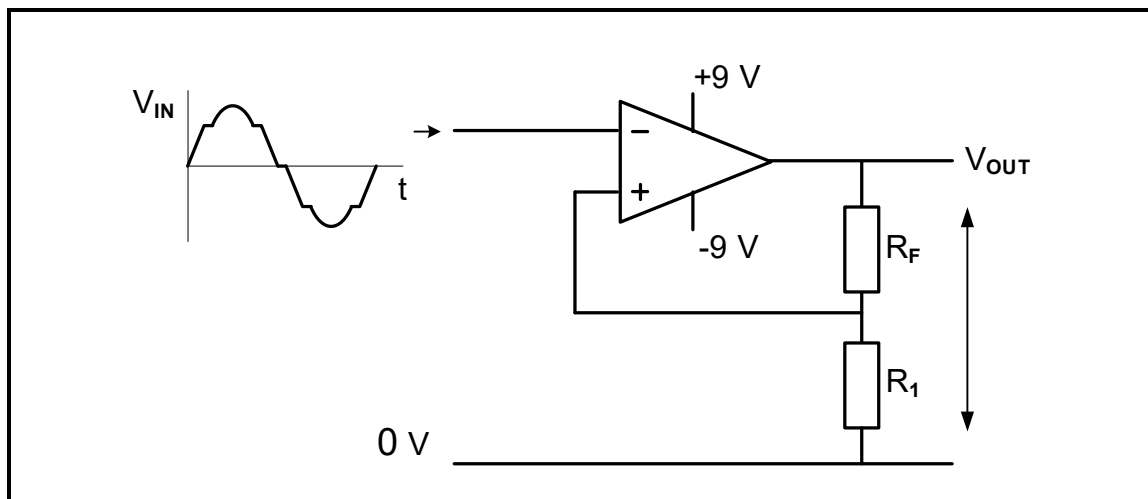

FIGURE 5.5: INVERTING SCHMITT TRIGGER

5.5.1 State TWO applications of Schmitt trigger circuits. (2)

5.5.2 Draw the output signal for the circuit in FIGURE 5.5 above on the ANSWER SHEET for QUESTION 5.5.2. (4)

5.6 Differentiate between a *Schmitt trigger* and a *comparator* with reference to their operation. (6)



5.7 FIGURE 5.7 and TABLE 5.7 below show the resistor values, output voltages and gain of a summing amplifier. Refer to FIGURE 5.7 and study TABLE 5.7 to answer the questions that follow.

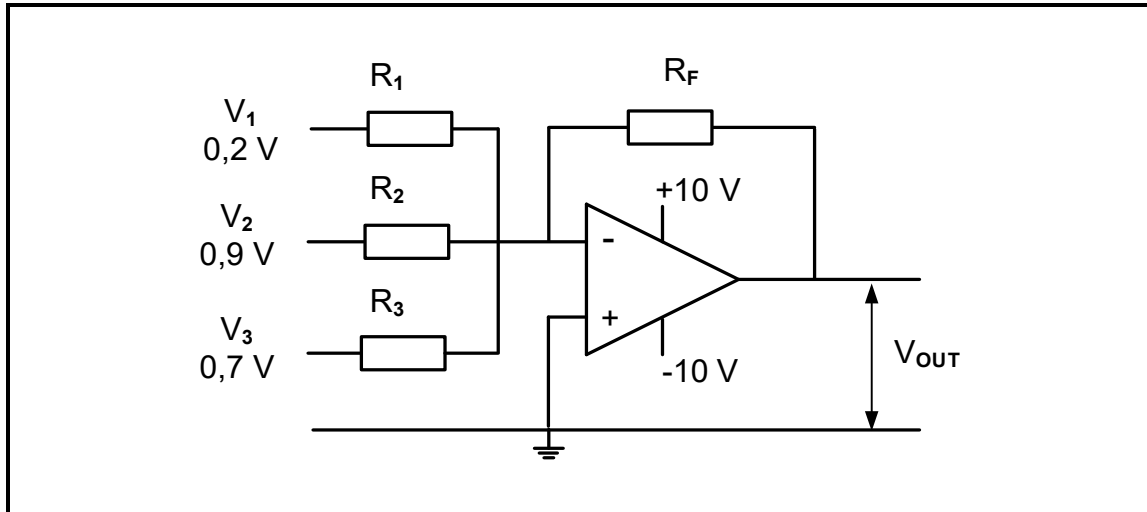

FIGURE 5.7: SUMMING AMPLIFIER

RESISTOR VALUES				OUTPUT	GAIN
R ₁	R ₂	R ₃	R _F	V _{OUT}	β (A _v)
10 kΩ	10 kΩ	10 kΩ	A	-1,8 V	B
33 kΩ	33 kΩ	33 kΩ	100 kΩ	C	-3,03
20 kΩ	20 kΩ	20 kΩ	100 kΩ	-9 V	D

TABLE 5.7

- 5.7.1 Determine the value of the feedback resistor at **A** in TABLE 5.7 above. (1)
 - 5.7.2 Determine the gain at **B** in TABLE 5.7 above. (1)
 - 5.7.3 Calculate the output voltage at **C** in TABLE 5.7 above. (3)
 - 5.7.4 Calculate the gain at **D** in TABLE 5.7 above. (3)
- 5.8 State TWO key operating principles of the op amp integrator circuit. (2)
- [50]**



QUESTION 6: AMPLIFIERS

- 6.1 Explain the concept of *linear amplification*. (2)
- 6.2 Refer to FIGURE 6.2 below and answer the questions that follow.

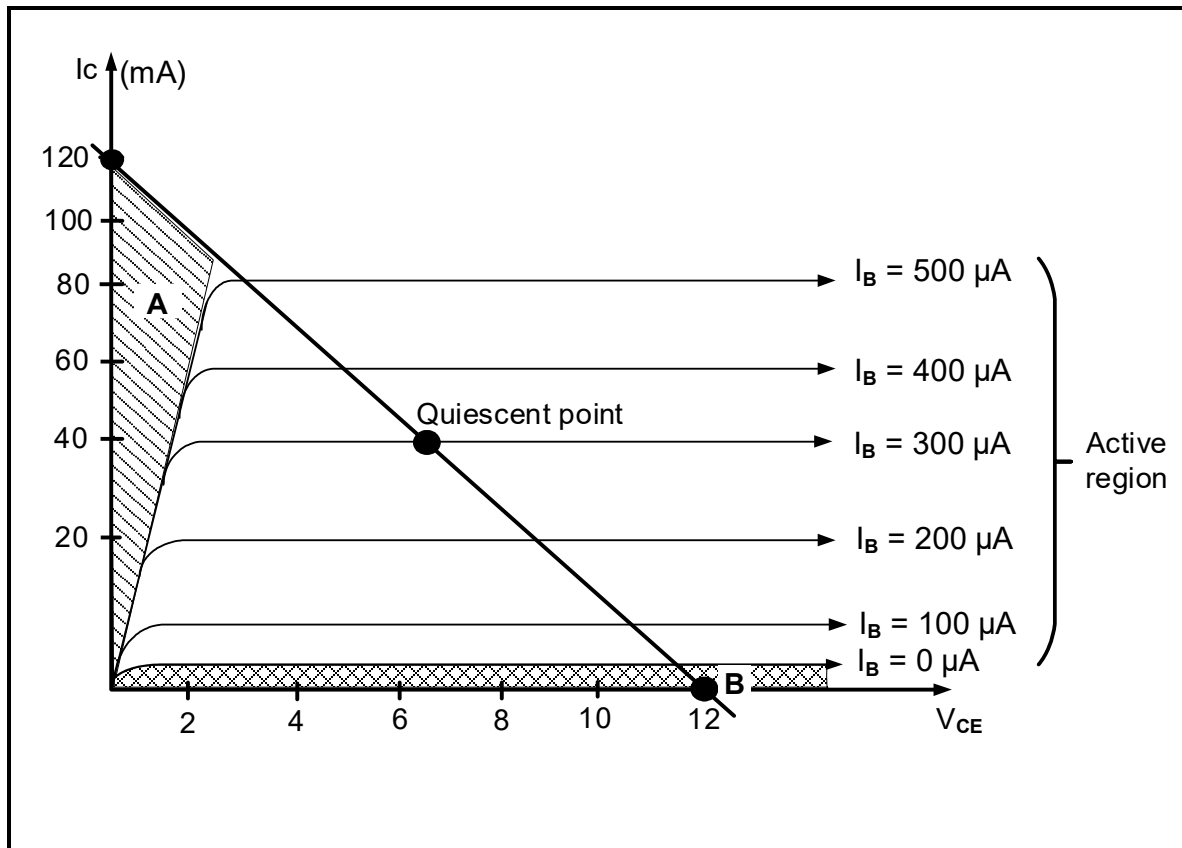

FIGURE 6.2: DC LOAD LINE

- 6.2.1 Name area **A** in FIGURE 6.2 above. (1)
- 6.2.2 Determine the value of the collector current at point **B** in FIGURE 6.2 above. (1)



6.3 Refer to FIGURE 6.3 and state the class of biasing that the characteristic curve in FIGURE 6.3 at **B** represents.

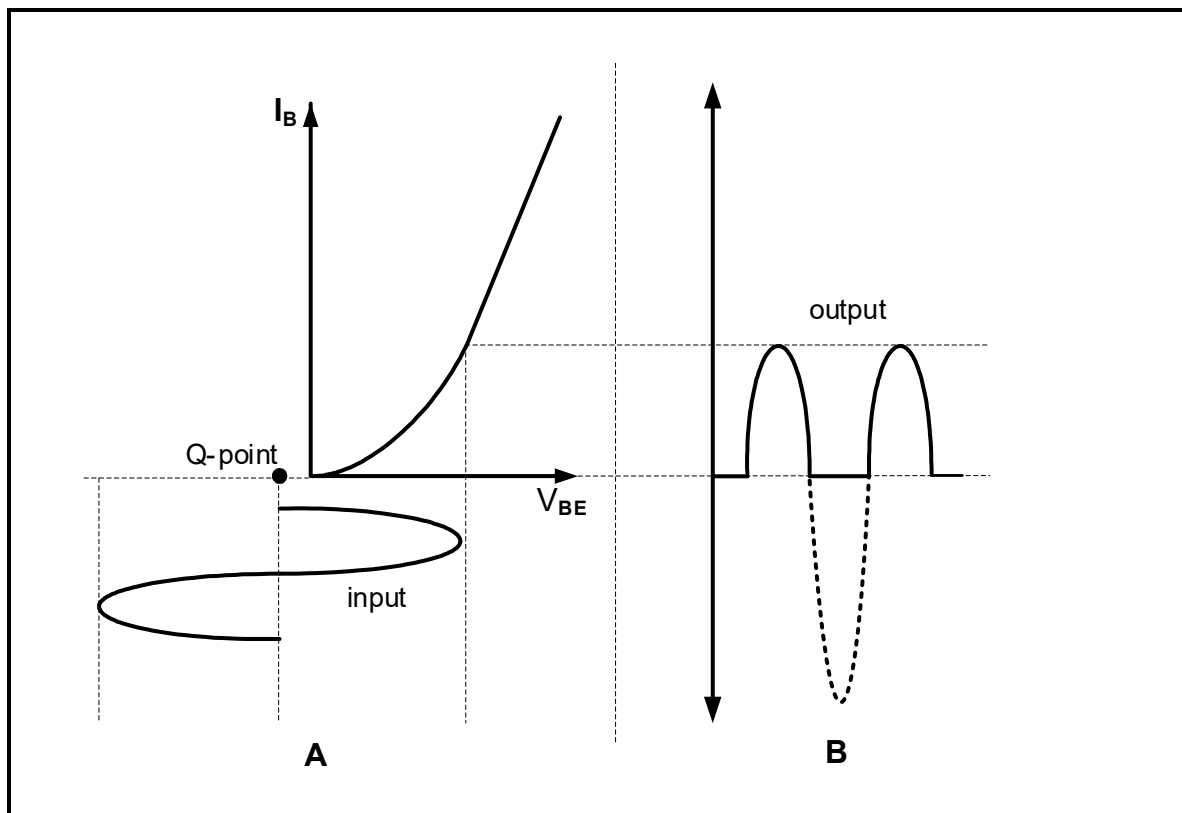

FIGURE 6.3: CHARACTERISTIC CURVE OF A BIPOLAR JUNCTION TRANSISTOR (BJT)

(1)

6.4 Refer to FIGURE 6.4 below and calculate the logarithmic gain in decibel when the multistage amplifier has the following values:

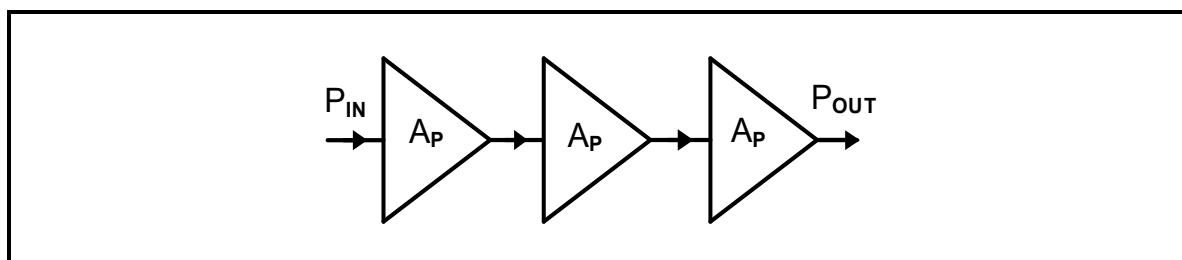

FIGURE 6.4: BLOCK DIAGRAM OF A MULTISTAGE AMPLIFIER

Given:

$P_{IN} = 0,5 \text{ W}$
 $P_{OUT} = 12 \text{ W}$

(3)



6.5 Refer to FIGURE 6.5 below and answer the questions that follow.

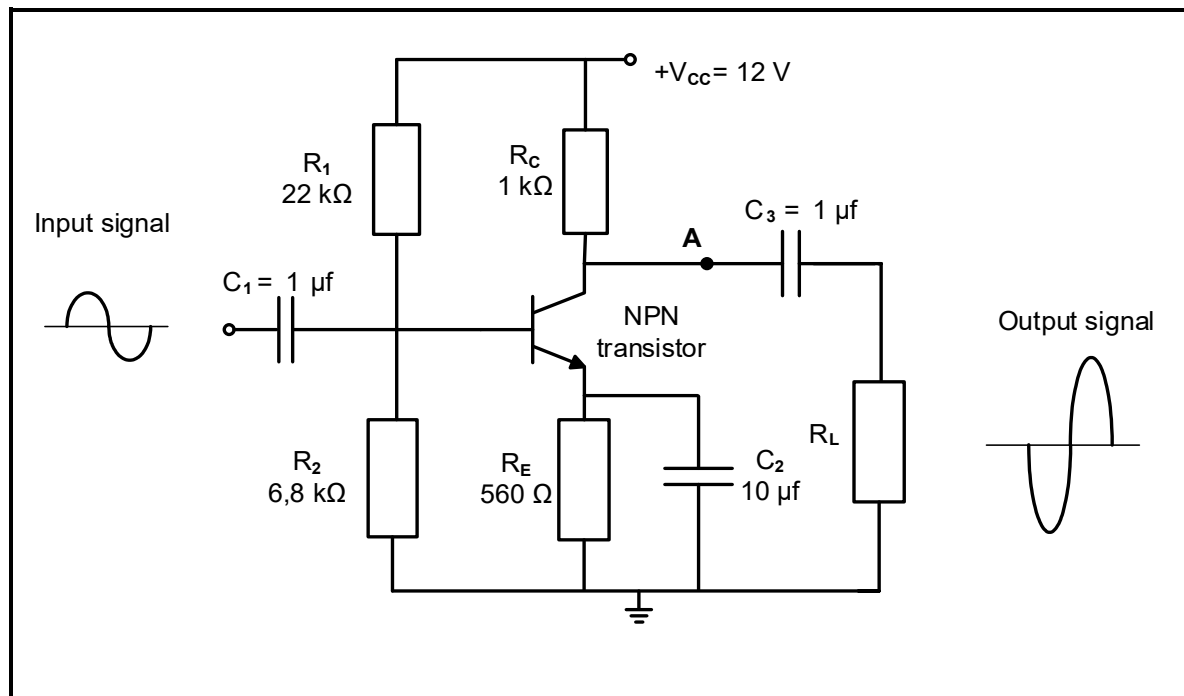

FIGURE 6.5: RC-COUPLED AMPLIFIER

- 6.5.1 Explain why C_1 and C_3 in FIGURE 6.5 above are referred to as bypass capacitors. (2)
- 6.5.2 Explain why the positive half-cycle of the input signal is 180° out of phase at the output. (2)
- 6.5.3 If the circuit in FIGURE 6.5 above is not correctly biased, what effect will it have on its operation? (2)
- 6.5.4 Draw the waveform that would appear at point **A** in FIGURE 6.5 above on the ANSWER SHEET for QUESTION 6.5.4. (4)



6.6 Refer to FIGURE 6.6 below and answer the questions that follow.

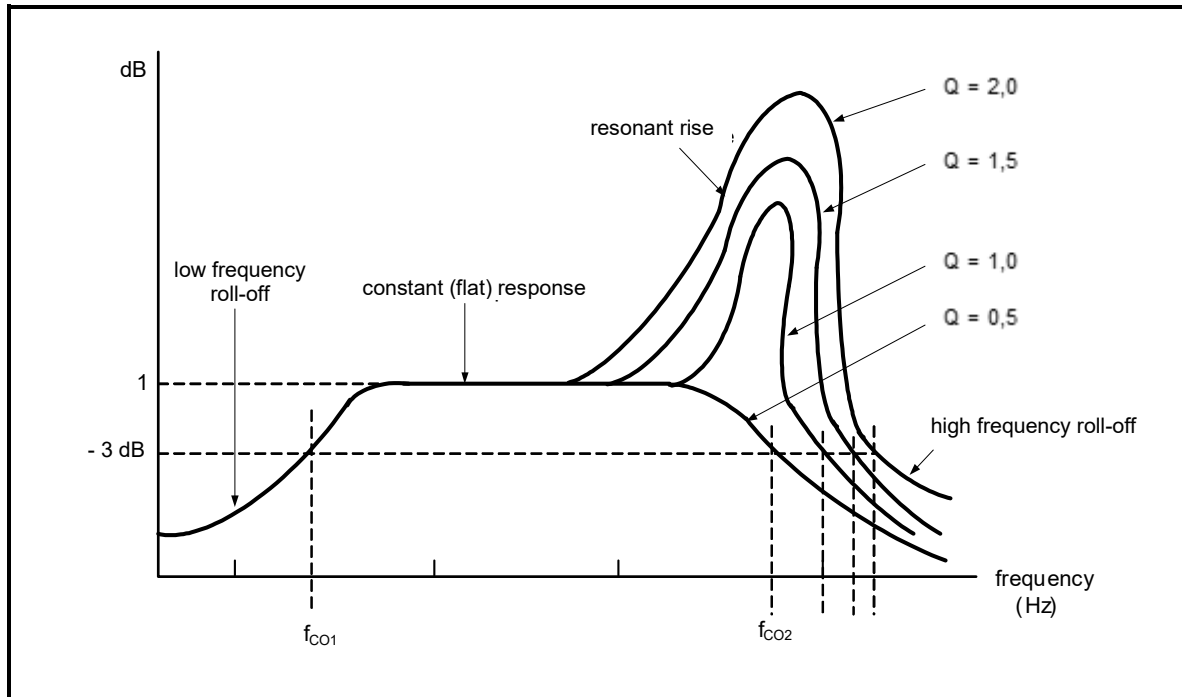

FIGURE 6.6: FREQUENCY RESPONSE CURVE

- 6.6.1 Identify the frequency response curve in FIGURE 6.6 above. (1)
- 6.6.2 Name the component that causes the resonant rise where $Q = 2,0$ in FIGURE 6.6 above. (1)
- 6.6.3 Explain why the frequency response curves have different roll-off values at higher frequencies. (2)



6.7 Refer to FIGURE 6.7 below and answer the questions that follow.

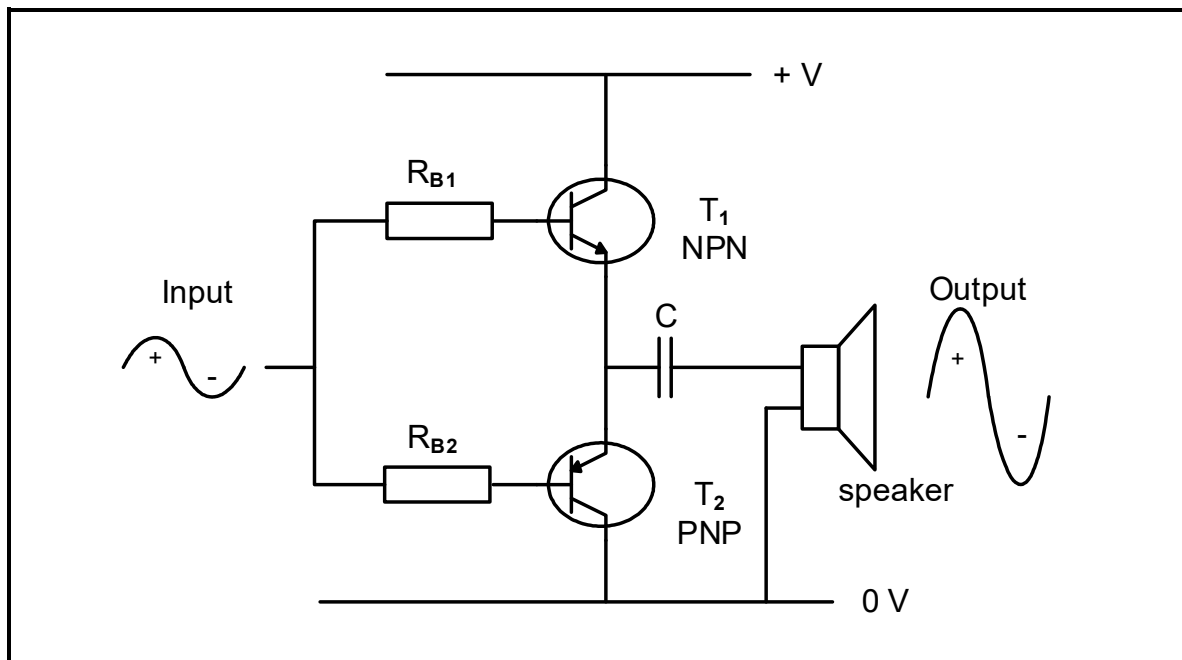

FIGURE 6.7: PUSH-PULL AMPLIFIER

- 6.7.1 Name which other device can be connected in FIGURE 6.7 above in place of the speaker. (1)
- 6.7.2 Name ONE application of a class B amplifier. (1)
- 6.7.3 Describe why pure class B amplification is not suitable for an audio amplifier. (2)
- 6.7.4 Draw the waveform that would appear across the PNP transistor on the ANSWER SHEET for QUESTION 6.7.4. (3)
- 6.8 Name TWO methods of coupling stages in the amplifier circuits. (2)



6.9 Refer to FIGURE 6.9 below and answer the questions that follow.

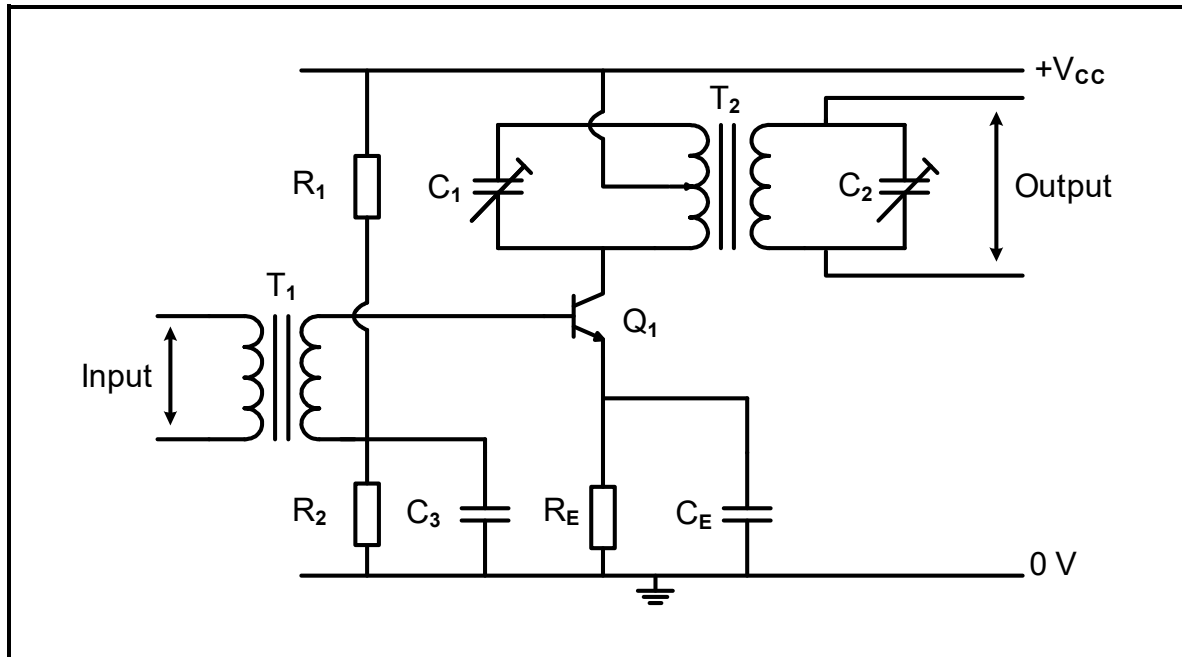

FIGURE 6.9: AMPLIFIER CIRCUIT DIAGRAM

- 6.9.1 Identify the amplifier circuit diagram in FIGURE 6.9 above. (1)
- 6.9.2 Explain why C_2 is connected in the secondary windings of T_2 . (2)
- 6.9.3 The gain of the amplifier circuit in FIGURE 6.9 above is 26 dB when the input power is 27 mW. Calculate the output power of the circuit. (3)



6.10 Refer to FIGURE 6.10 below and answer the questions that follow.

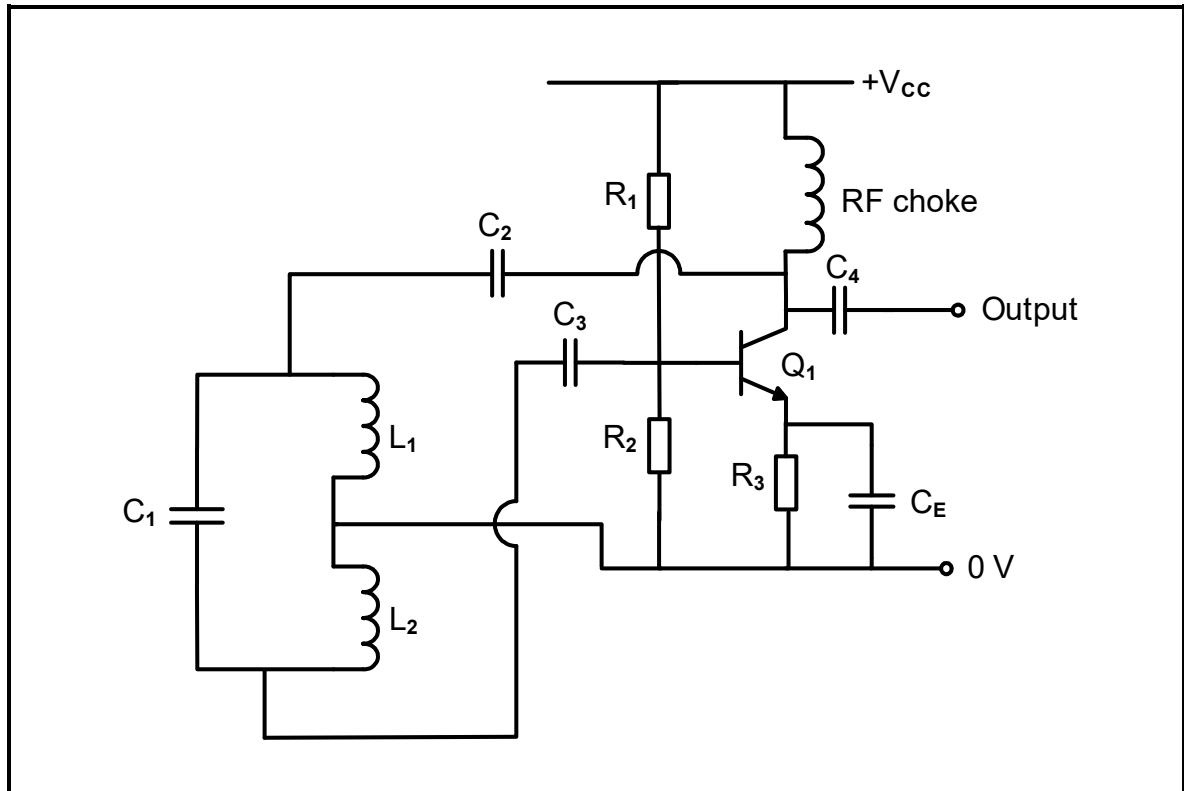

FIGURE 6.10: HARTLEY OSCILLATOR

- 6.10.1 Name ONE condition for the circuit in FIGURE 6.10 above to produce a sustained sinusoidal output waveform. (1)
- 6.10.2 Briefly describe the function of the coupling capacitors C_2 and C_3 . (2)



6.11 Refer to FIGURE 6.11 below and answer the questions that follow.

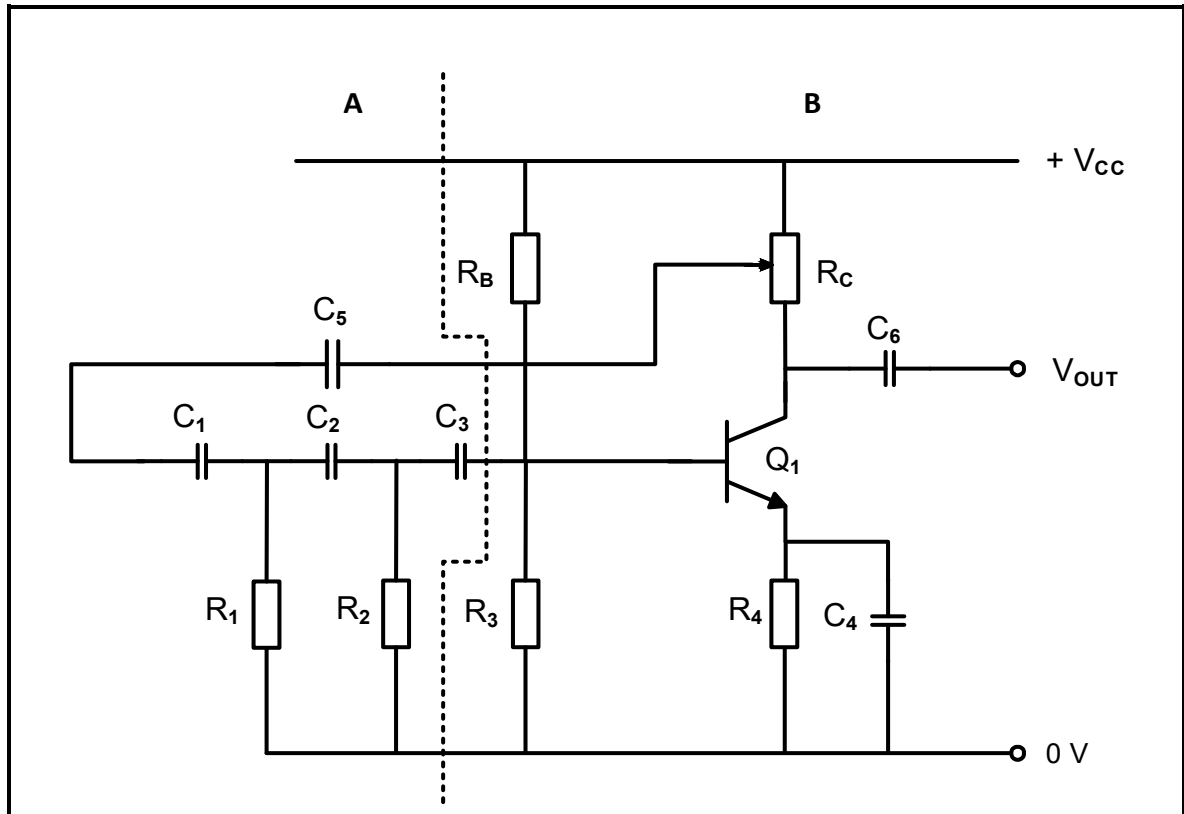

FIGURE 6.11: OSCILLATOR

- 6.11.1 Identify the oscillator in FIGURE 6.11 above. (1)
- 6.11.2 Name **A** and **B** in FIGURE 6.11 above. (2)
- 6.11.3 Explain how the circuit in FIGURE 6.11 above obtains a 360° phase shift. (2)

[45]

TOTAL: 200



FORMULA SHEET

RLC CIRCUITS	SEMICONDUCTOR DEVICES
<p>$P = V I \cos \theta$ $X_L = 2\pi fL$</p> <p>$X_C = \frac{1}{2\pi fC}$</p> <p>$f_r = \frac{1}{2\pi\sqrt{LC}}$ OR $f_r = \frac{f_2 + f_1}{2}$</p> <p>$BW = \frac{f_r}{Q}$ OR $BW = f_2 - f_1$</p> <p>Series $V_R = IR$ $V_L = I X_L$ $V_C = I X_C$</p> <p>$I_T = \frac{V_T}{Z}$ OR $I_T = I_R = I_C = I_L$</p>	<p>Gain $A_V = \frac{V_{OUT}}{V_{IN}} = -\frac{R_F}{R_{IN}}$ $A_V = 1 + \frac{R_F}{R_{IN}}$</p> <p>$V_{OUT} = V_{IN} \times \left(-\frac{R_F}{R_{IN}}\right)$</p> <p>$V_{OUT} = V_{IN} \left(1 + \frac{R_F}{R_{IN}}\right)$</p>
<p>$Z = \sqrt{R^2 + (X_L - X_C)^2}$</p> <p>$V_T = \sqrt{V_R^2 + (V_L - V_C)^2}$ OR $V_T = IZ$</p> <p>$\cos \theta = \frac{R}{Z}$ OR $\cos \theta = \frac{V_R}{V_T}$ OR $\tan \theta = \frac{V_L - V_C}{V_R}$</p> <p>$Q = \frac{X_L}{R} = \frac{X_C}{R} = \frac{V_L}{V_T} = \frac{V_C}{V_T} = \frac{1}{R} \sqrt{\frac{L}{C}}$</p>	<p>SWITCHING CIRCUITS</p> <p>$V_{OUT} = -\left(V_1 \frac{R_F}{R_1} + V_2 \frac{R_F}{R_2} + \dots + V_N \frac{R_F}{R_N}\right)$</p> <p>Gain $A_V = \frac{V_{OUT}}{V_{IN}} = \frac{V_{OUT}}{(V_1 + V_2 + \dots + V_N)}$</p> <p>$V_{OUT} = -(V_1 + V_2 + \dots + V_N)$</p>
<p>Parallel $V_T = V_R = V_L = V_C$</p> <p>$I_R = \frac{V_T}{R}$</p> <p>$I_C = \frac{V_T}{X_C}$</p> <p>$I_L = \frac{V_T}{X_L}$</p> <p>$I_T = \sqrt{I_R^2 + (I_C - I_L)^2}$</p> <p>$Z = \frac{V_T}{I_T}$</p> <p>$\cos \theta = \frac{I_R}{I_T}$</p> <p>$Q = \frac{R}{X_L} = \frac{R}{X_C}$</p>	<p>AMPLIFIERS</p> <p>$I_C = \frac{V_C}{R_C}$ $V_{CC} = V_{CE} + I_C R_C$</p> <p>$V_B = V_{BE} + V_{RE}$</p> <p>$A_V = \frac{V_{OUT}}{V_{IN}}$</p> <p>$A_I = \frac{I_{OUT}}{I_{IN}}$</p> <p>$A_P = \frac{P_{OUT}}{P_{IN}}$ OR $A_P = A_V \times A_I$</p> <p>$\beta_T = \beta_1 \times \beta_2$ OR $A_{VT} = A_{V1} \times A_{V2} \times A_{V3} \times \dots \times A_{Vn}$</p> <p>$P_{IN} = I^2 \times Z_{IN}$ AND $P_{OUT} = I^2 \times Z_{OUT}$</p> <p>Oscillation frequency</p> <p>$f_o = \frac{1}{2 \times \pi \sqrt{LC}}$ OR $f_o = \frac{1}{2 \times \pi \sqrt{6RC}}$</p> <p>GAIN IN DECIBELS</p> <p>$A_I = 20 \log_{10} \frac{I_{OUT}}{I_{IN}}$</p> <p>$A_V = 20 \log_{10} \frac{V_{OUT}}{V_{IN}}$ OR $A_V = 20 \log_{10} A_{VT}$</p> <p>$A_P = 10 \log_{10} \frac{P_{OUT}}{P_{IN}}$ OR $A_P = 10 \log_{10} \frac{P_2}{P_1}$</p>

