

Confidential



basic education

Department:
Basic Education
REPUBLIC OF SOUTH AFRICA

SENIOR CERTIFICATE EXAMINATIONS/ NATIONAL SENIOR CERTIFICATE EXAMINATIONS

CIVIL TECHNOLOGY: CONSTRUCTION

MAY/JUNE 2025

MARKS: 200

TIME: 3 hours

This question paper consists of 14 pages and 6 answer sheets.



REQUIREMENTS:

1. Drawing instruments
2. A non-programmable calculator
3. ANSWER BOOK

INSTRUCTIONS AND INFORMATION

1. This question paper consists of SIX questions.
2. Answer ALL the questions.
3. Read ALL the questions carefully.
4. Answer each question as a whole. Do NOT separate subsections of questions.
5. Number the answers correctly according to the numbering system used in this question paper.
6. Start the answer to EACH question on a NEW page.
7. Do NOT write in the margins of the ANSWER BOOK.
8. You may use sketches to illustrate your answers.
9. Write ALL calculations and answers in the ANSWER BOOK or on the attached ANSWER SHEETS.
10. Use the mark allocation as a guide to the length of your answers.
11. Make drawings and sketches in pencil, fully dimensioned and neatly finished off with descriptive titles and notes to conform to the *SANS/SABS Code of Practice for Building Drawings*.
12. For the purpose of this question paper, the size of a brick should be taken as 220 mm x 110 mm x 75 mm.
13. Use your own discretion where dimensions and/or details have been omitted.
14. Answer QUESTIONS 2, 3.9, 4.7, 5.5, 5.6 and 6.5 on the attached ANSWER SHEETS using drawing instruments, where necessary.
15. Write your CENTRE NUMBER and EXAMINATION NUMBER on every ANSWER SHEET and hand them in with your ANSWER BOOK, whether you have used them or not.
16. Drawings in the question paper are NOT to scale due to electronic transfer.
17. Google Images was used as the source of all photographs and pictures.
18. Write neatly and legibly. ...



QUESTION 1: OHSA, MATERIALS, TOOLS, EQUIPMENT AND JOINING (GENERIC)

Start this question on a NEW page.

1.1 Choose the correct answer(s) from those given in brackets. Write only the word(s) next to the question numbers (1.1.1 to 1.1.10) in the ANSWER BOOK, e.g. 1.1.11 Wood.

- 1.1.1 Materials are preserved by (venereing/curing/powder coating) to make them sustainable. (1)
- 1.1.2 This preservation method, (electroplating/annealing/painting), will not protect metal from rust. (1)
- 1.1.3 (Electrolysis/Galvanising/Paint) is available in an oil or water base. (1)
- 1.1.4 Under normal circumstances, scaffold frameworks should be inspected (weekly/bi-weekly/daily). (1)
- 1.1.5 When working on scaffolding (sharp corners may be left uncovered/do not jump from one level to another on the scaffold/throw materials from the scaffold). (1)
- 1.1.6 An employer shall ensure that the outriggers/frames of suspended scaffolds are constructed of (steel/copper/lead). (1)
- 1.1.7 Trestle scaffolds may not consist of more than (2/3/4) tiers. (1)
- 1.1.8 Every employer who uses any hazardous chemical substances at work, should be in possession of (a medical aid/a material safety data sheet/an authorisation letter). (1)
- 1.1.9 Never extend a ladder more than (one quarter/two thirds/one third) of the extension length. (1)
- 1.1.10 The recommended height for the gates of the builder's hoist is at least (1 980 mm/1 250 mm/1 550 mm). (1)

1.2 The nuts below are used to fasten bolts.

1.2.1 Which top view represents a nut with a built-in washer?



A



B

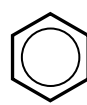

C



D

(1)



1.2.2 What is the purpose of the square section of the fastener as indicated by A?

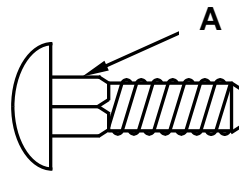

(1)

1.2.3 Rearrange the pictures below in the correct sequence:

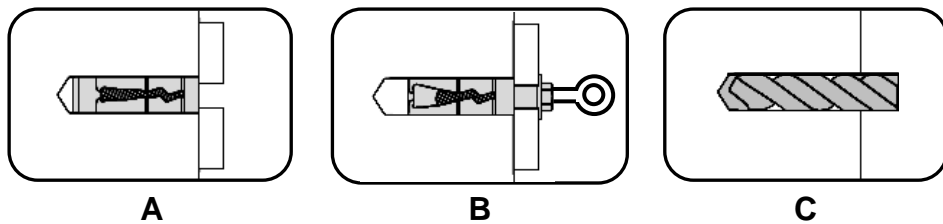

(1)

1.2.4 The specification for a Rawl bolt is R-RBL-M08/25. What does the number 25 represent?

(1)

1.3 Explain TWO advantages of galvanising. (2)

1.4 Name ONE natural element that a multi-detector must be protected against. (1)

1.5 Describe why you will use a laser level when installing a shelf against a wall. (1)

1.6 Name TWO accessories that must be used with the telescope of the dumpy level to take an accurate reading. (2)

[20]

QUESTION 2: GRAPHICS AS MEANS OF COMMUNICATION (GENERIC)

Start this question on a NEW page.

FIGURE A and FIGURE B on the next page show drawings that appear on a building plan. Analyse the drawings and complete the table on ANSWER SHEET 2.



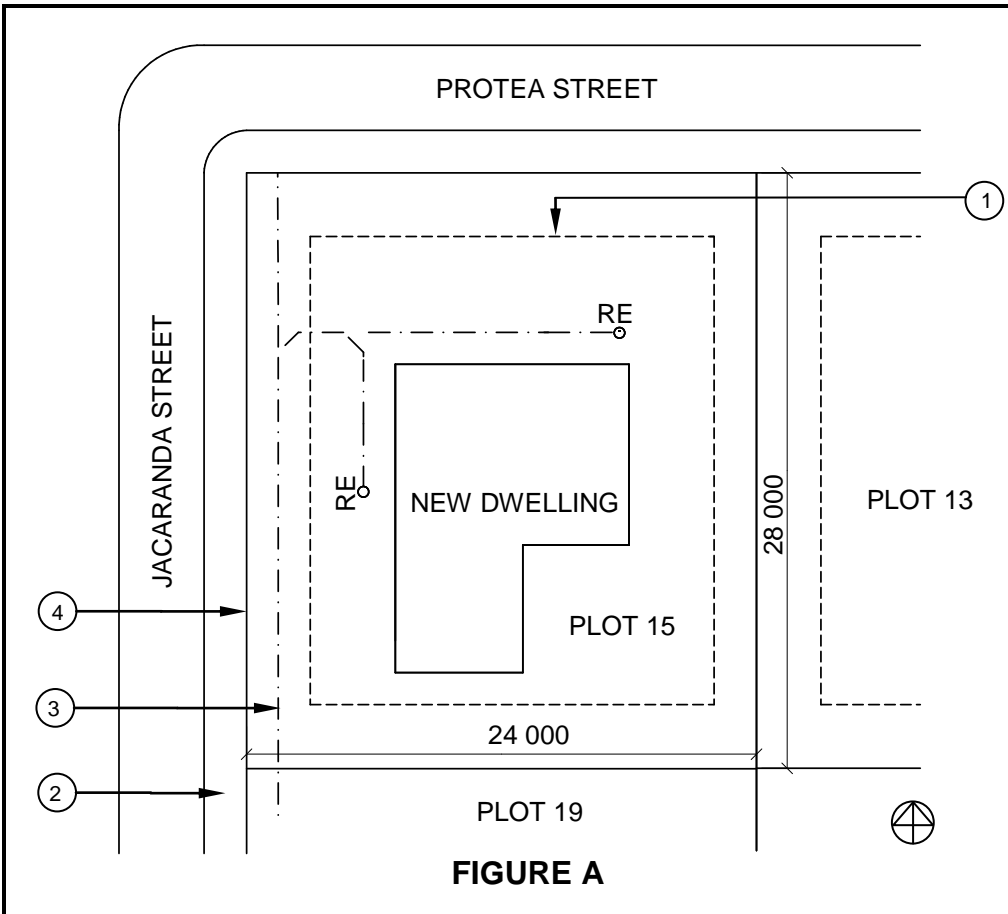

NOTES:

Contractors must verify all dimensions and levels on site before commencing work.

Architects to be notified of any discrepancies immediately.

Bedroom lights: 2 x 6 W (LED)

Fencing: Pre-fabricated fencing

Sidewalk next to number 4 = 1 500 mm

Architect's signature

Client's signature

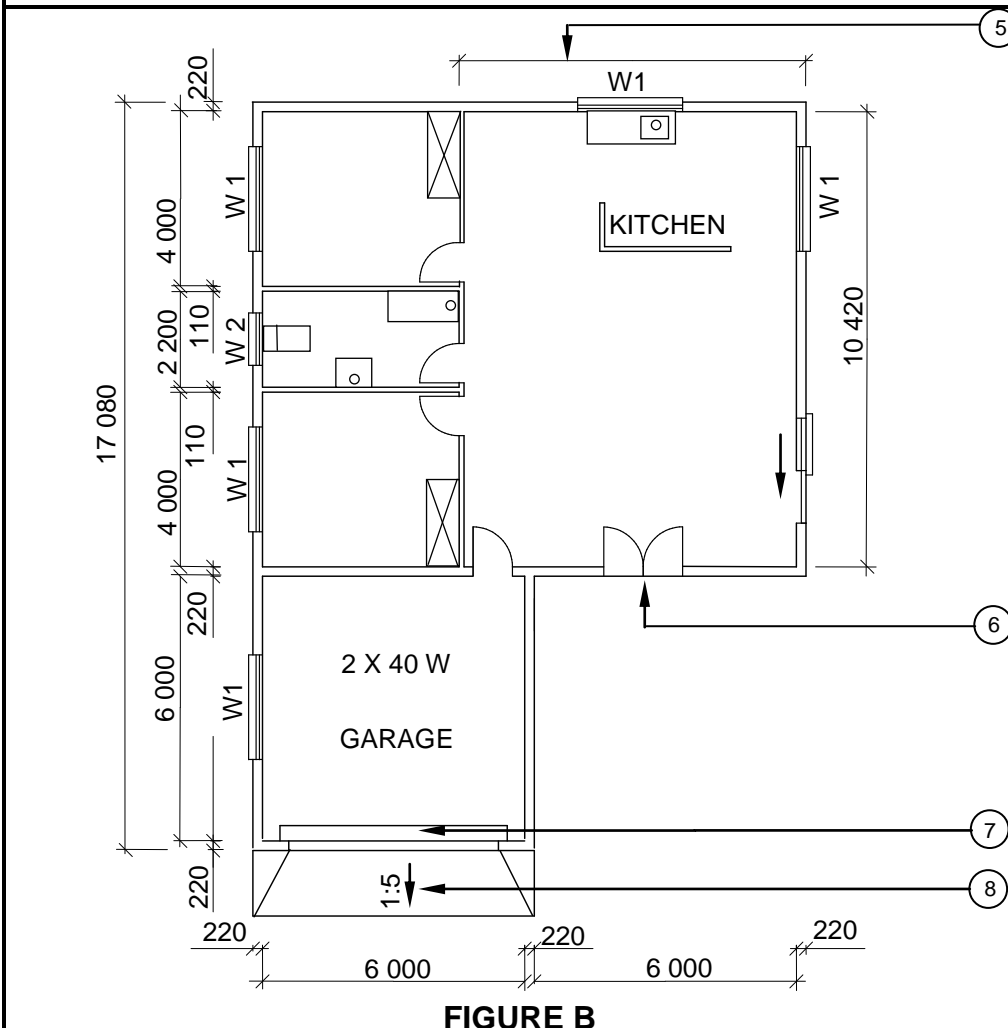

REVISION 1	DATE: 16/02/2025	DRAWING OF BATHROOM FIXTURES
PRINTED BY: DOCK PRINTERS		DATE OF PRINT: 18/04/2025
DRAWING TITLE: SITE PLAN AND FLOOR PLAN		
PROJECT: PROPOSED DWELLING OF MS TOMEY ON PLOT 15, PALM STREET, PHOENIX		
PROJECT NO.: GR 288-229	DRAWING NO.: 668P8	
DATE: 08/04/2025	DRAWN: P COX	CHECKED: D FOX
SITE PLAN	SCALE: 1 : 500	
FLOOR PLAN	SCALE 1 : 100	

REFERENCE CODE
QP 8 – 2025

WINDOW SCHEDULE

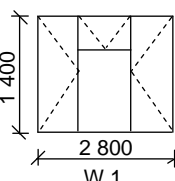
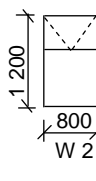
 1 400 2 800 W 1	 1 200 800 W 2
--	--

[40]



QUESTION 3: ROOFS, STAIRCASES AND JOINING (SPECIFIC)

Start this question on a NEW page.

- 3.1 Joining methods is an integral part of construction.
- 3.1.1 Name TWO roof components that can be joined to walls and brickwork on top of the superstructure. (2)
- 3.1.2 Give a reason why a baseplate is anchored to concrete. (1)
- 3.2 By means of neat, vertical section sketches, differentiate between a *batten* and a *foot batten*. Print the title and dimensions below each drawing. (4)
- 3.3 What is the recommended minimum head room dimension, from the pitch line to the ceiling, of a staircase? (1)
- 3.4 Explain the purpose of the apron as used in a staircase. (1)
- 3.5 Give the recommended striking time for the sides of the staircase. (1)
- 3.6 What is the combination of a single *tread* and *riser* called? (1)
- 3.7 State the recommended dimensions (schedule) for a tread and riser for a public building. (2)
- 3.8 Name TWO types of balustrade patterns. (2)
- 3.9 Use ANSWER SHEET 3.9 and draw to scale 1 : 20 only the left half of a SA (Howe) roof truss. Print the labels of any TWO parts.

Use the following specifications:

- The total internal span is 6 000 mm.
- The overhang is 300 mm.
- The pitch of the roof is 30°.
- The roof truss is made of 114 x 38 mm timber.

NOTE: Use the breakline on the ANSWER SHEET as reference.

(15)
[30]



QUESTION 4: EXCAVATIONS, FORMWORK, TOOLS, EQUIPMENT AND MATERIALS (SPECIFIC)

Start this question on a NEW page.

- 4.1 Give ONE word/term for EACH of the following descriptions by choosing a word/term from the list below. Write only the word/term next to the question numbers (4.1.1 to 4.1.5) in the ANSWER BOOK, e.g. 4.1.6 Basic sealant.

drainage systems; Perspex; glass; light; smooth; hot-water pipes;
ductile cast iron; highly toxic; rough; brass; hardboard; grey cast iron

- 4.1.1 Very hard, but breaks easily and is brittle (1)
- 4.1.2 Lead has a low melting point as well as this unique property (1)
- 4.1.3 Alloy of copper and zinc, in which copper is the main ingredient (1)
- 4.1.4 An alternative material used instead of glass (1)
- 4.1.5 PVC is used for this purpose in household pipes (1)
- 4.2 Various options are provided as possible answers to the following questions. Choose the answer and write only the letter (A–D) next to the question numbers (4.2.1 to 4.2.5) in the ANSWER BOOK, e.g. 4.2.6 D.
- 4.2.1 Wheel stoppers can be installed ... from the trench. (1)
- A 1,2 metres
B 800 mm
C 1 metre
D 400 mm
- 4.2.2 Workers working in excavations, must wear ... and protective clothing. (1)
- A safety boots
B overalls
C hard hats
D All the above-mentioned
- 4.2.3 Precautions that must be taken at night to keep trenches safe: (1)
- A Clean the site
B Shuttering should be removed
C Fence off the area
D Back filling should be done



- 4.2.4 After the site inspection, one of the main objectives when preparing a site is to
- A dig a trench.
 - B establish a baseline.
 - C erect formwork.
 - D start with excavations. (1)

- 4.2.5 Bracing keeps sides firm while ... is taking place.
- A backfilling
 - B excavation
 - C inspection
 - D training (1)

- 4.3 FIGURE 4.3 below shows a construction machine that is used on a building site.



FIGURE 4.3

- 4.3.1 Identify this construction machine. (1)
- 4.3.2 Explain how this machine should be taken care of after it has been cleaned and cleared of all loose soil and dirt. (2)



4.4 FIGURE 4.4 below shows the apparatus that is used to test concrete on a construction site.



FIGURE 4.4

4.4.1 What test is carried out on concrete when using the apparatus? (1)

4.4.2 Describe the purpose of this test. (3)

4.4.3 Name the THREE outcomes of this test. (3)

4.5 Name TWO properties of steel shuttering used for formwork. (2)

4.6 What will you use to level formwork? (2)

4.7 ANSWER SHEET 4.7 shows the undisturbed earth of an excavation of a shallow trench.

Use ANSWER SHEET 4.7 and draw, in good proportion, a vertical sectional view of the shuttering for the excavated trench. Print any TWO labels. (12)



4.8 FIGURE 4.8 below shows formwork used on a construction site.

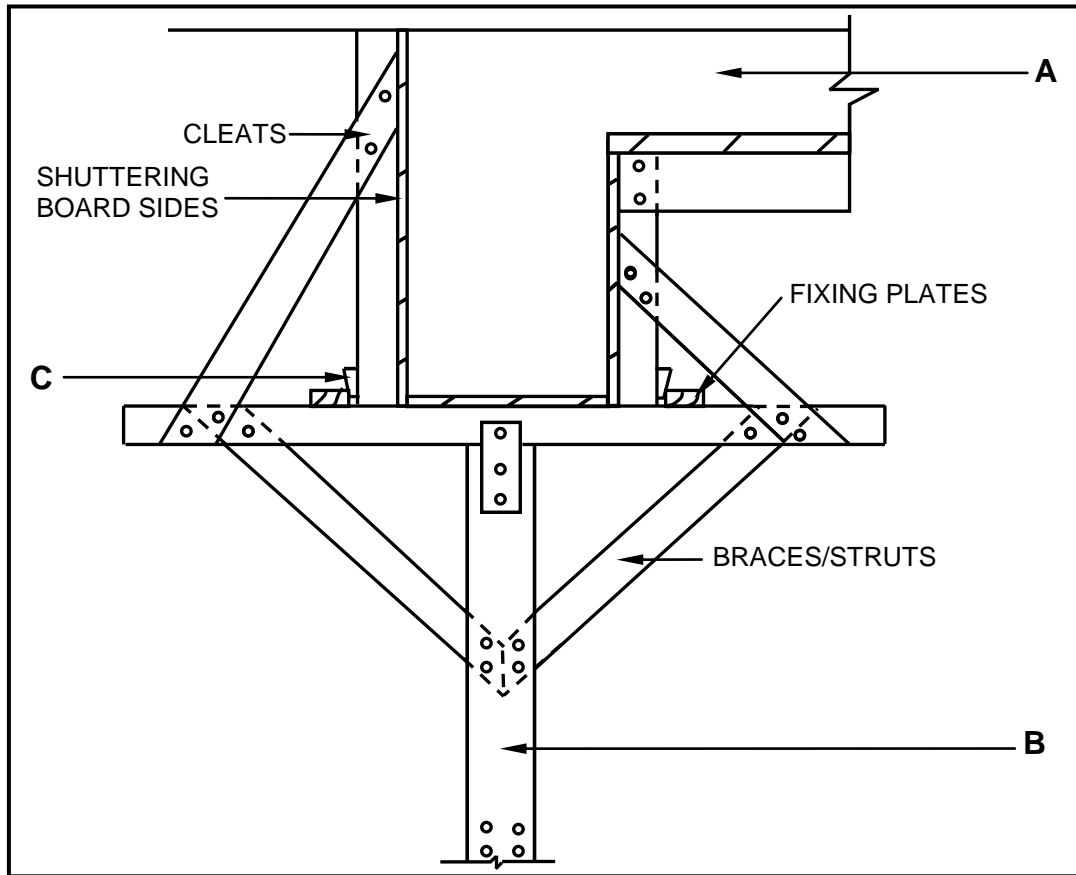

FIGURE 4.8

- 4.8.1 Name the type of formwork. (1)
 - 4.8.2 Identify **A**, **B** and **C**. (3)
- [40]



QUESTION 5: PLASTER AND SCREED, BRICKWORK AND GRAPHICS AS MEANS OF COMMUNICATION (SPECIFIC)

Start this question on a NEW page.

- 5.1 Describe the term *bagging finish* when applied to a plastered wall. (2)
- 5.2 Explain the process of finishing a plastered wall after the plaster has been levelled with a straight edge. (2)
- 5.3 Explain the process you will follow to prepare for casting a bonded screed to the dry surface of a concrete floor. (4)
- 5.4 FIGURE 5.4 below shows a sectional view of a cavity wall.

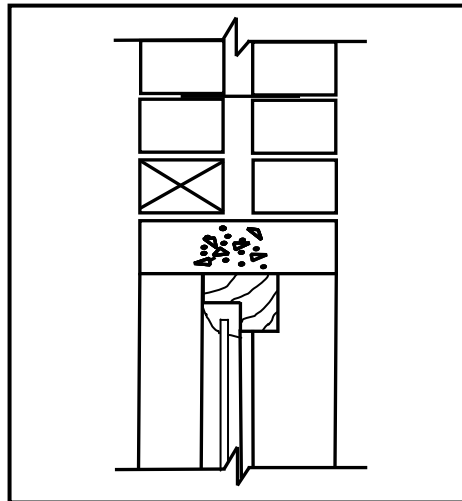

FIGURE 5.4

- 5.4.1 Explain why wall ties are used in the cavity walls. (1)
- 5.4.2 Describe where you will insert the DPC in a cavity wall. (2)
- 5.4.3 Draw a sketch of a butterfly wall tie. (2)
- 5.5 ANSWER SHEET 5.5 shows an incomplete drawing of the construction of paving blocks in a basket weave pattern with a free edge. Complete the drawing and print any THREE labels. Indicate the symbol for concrete. (9)
- 5.6 ANSWER SHEET 5.6 shows a horizontal sectional view of a 220 mm wall. Draw the horizontal sectional view of a timber door frame built into the wall. Label any ONE part. (8)

[30]



QUESTION 6: REINFORCEMENT IN CONCRETE, FOUNDATIONS, CONCRETE FLOORS AND QUANTITIES (SPECIFIC)

Start this question on a NEW page.

6.1 Choose a description from COLUMN B that matches the item in COLUMN A. Write only the letter (A–H) next to the question numbers (6.1.1 to 6.1.5) in the ANSWER BOOK, e.g. 6.1.6 J.

COLUMN A		COLUMN B	
6.1.1	Spacing of ribs	A	can be used for electrical, plumbing and security services as well as communications
6.1.2	Hollow core blocks	B	is approximately 650 mm apart
6.1.3	End bearings of ribs	C	should be at least 220 mm wide
6.1.4	Props	D	should be at least 110 mm wide
6.1.5	Load-bearing walls	E	is dependent on the width of the hollow core block
		F	can be removed after the concrete has reached 17 MPa
		G	must rest at least 90 mm on the walls that are perpendicular to the ribs
		H	can be removed after the concrete has reached 4 MPa

(5 x 1) (5)



6.2 FIGURE 6.2 below shows a driven in-situ pile being installed.

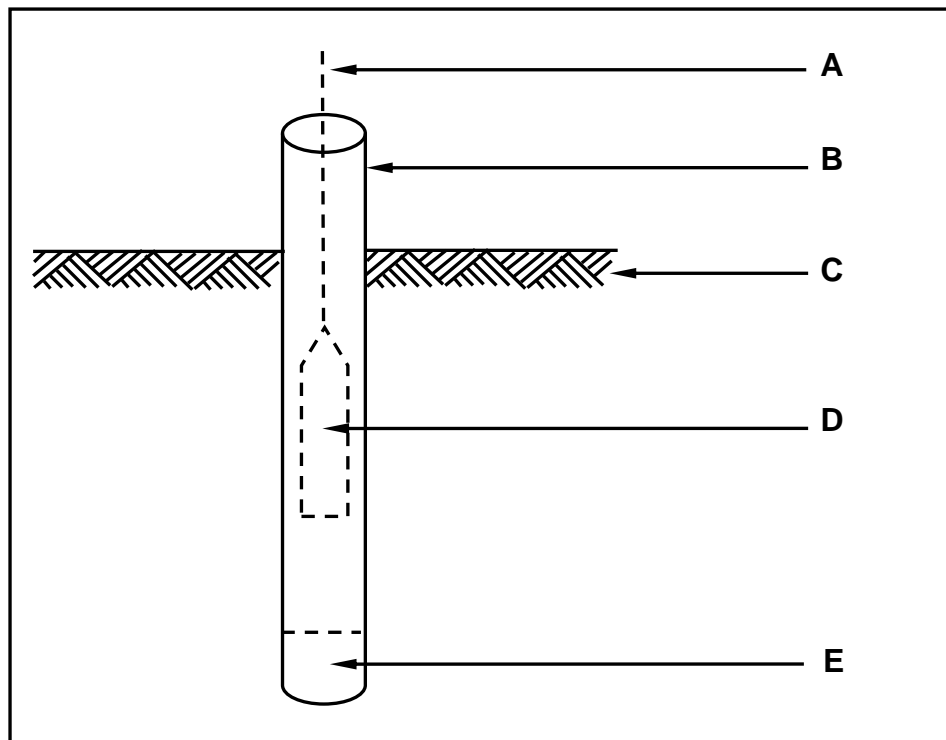

FIGURE 6.2

- 6.2.1 Identify parts **A**, **B**, **C**, **D** and **E**. (5)
- 6.2.2 Draw a neat sketch of part **E** after the process has been completed. Indicate the symbol for concrete. (3)
- 6.2.3 Explain the function of **D** in the process. (1)
- 6.2.4 Describe what happens to part **B** after the process has been completed. (1)
- 6.2.5 Explain under what conditions this type of pile can be used. (1)
- 6.2.6 Name ONE other type of pile that can be used instead of the one in FIGURE 6.2. (1)
- 6.2.7 State ONE advantage of using part **B**. (1)



6.3 FIGURE 6.3 below shows a type of floor construction.

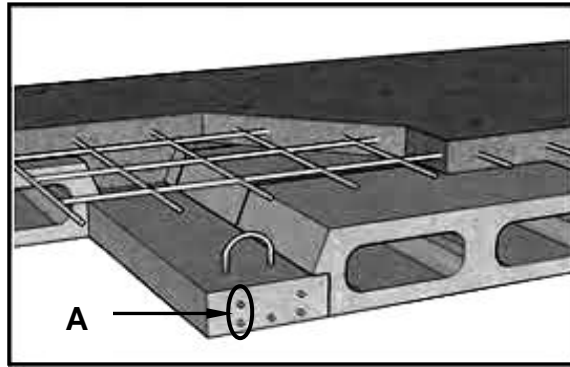

FIGURE 6.3

6.3.1 Identify A. (1)

6.3.2 What is the purpose of A? (1)

6.4 By means of TWO sketches, differentiate between a *compression force* and a *shear force*. Print the correct title under EACH drawing. (4)

6.5 FIGURE 6.5 below shows the floor plan of a large storage room.

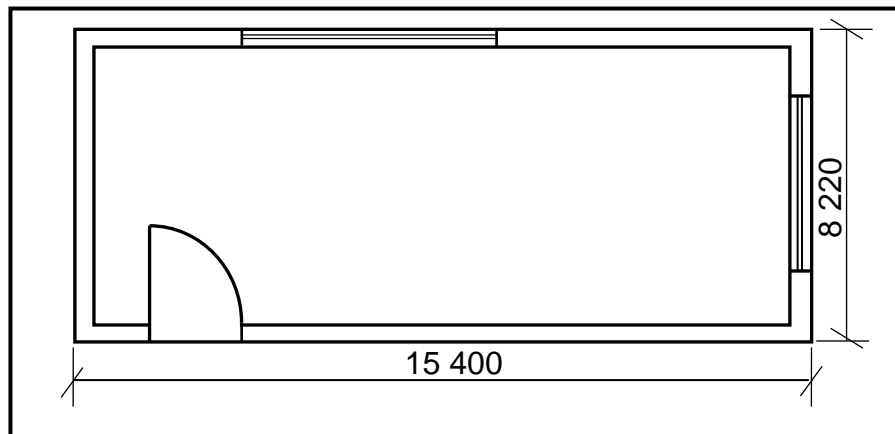

FIGURE 6.5

Use the following specifications:

- The screed is 30 mm thick.
- The width of the external walls is 220 mm.

Use the dimension paper on ANSWER SHEET 6.5 and calculate the following. Round off your answers to TWO decimals.

6.5.1 Volume of screed for the building (9)

6.5.2 Area of tiles needed, including 5% of the area to provide for breakage (6)

NOTE: A mark will be awarded for the correct use of the dimension paper. (1)
[40]

TOTAL: 200



CENTRE NUMBER:

EXAMINATION NUMBER:

ANSWER SHEET 2

NO.	QUESTIONS	ANSWERS	MARKS
1.	What is the measurement of the dwelling facing Jacaranda Street?		1
2.	Identify number 1.		1
3.	Identify number 2.		1
4.	Identify number 3.		1
5.	Identify the number indicating the boundary line.		1
6.	Name the colour that must be used to indicate the new dwelling on the site plan.		1
7.	What is omitted at number 6 if the NGL is 300 mm lower than the FFL?		1
8.	What type of fencing is used for the boundary wall for plot number 15?		1
9.	Name TWO materials that can be used for number 7.		2
10.	What is wrong with number 8?		1
11.	Name THREE electrical installations omitted in the house.		3
12.	Which plot is on the eastern side of the new dwelling?		1



13.	Identify the elevation with no windows.		1
14.	How many rodding eyes are shown on the site plan?		1
15.	How many external doors are there on the plan for the house?		1
16.	Which street is on the western side of the new dwelling?		1
17.	How many 1 200 mm x 800 mm windows are in the building?		1
18.	On what date was revision 1 completed?		1
19.	Draw the symbol for a wall-mounted urinal.		2
20.	Draw the symbol for a double-pole one-way switch.		3
21.	Draw the symbol for a staircase.		3
22.	Deduce from the notes column the type of globes that will be used in the bedroom.		1
23.	In which town will the new dwelling be erected?		1



24.	Calculate the total length of fencing that would be needed to fence plot number 15 . Give your answer in metres and show ALL your calculations.		6
25.	The internal area of the open plan kitchen is 72,94 m ² . Calculate the length of number 5 . Give your answer in mm.		3
		TOTAL:	40



CENTRE NUMBER:

EXAMINATION NUMBER:

ANSWER SHEET 3.9

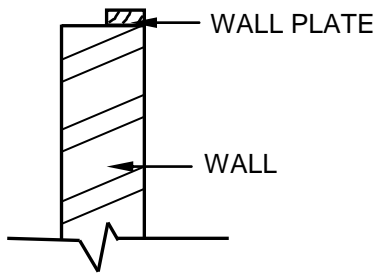

ASSESSMENT CRITERIA		
NO.	MARK	CANDIDATE'S MARK
1	2	
2	2	
3	2	
4	2	
5	2	
6	1	
7	2	
8	2	
TOTAL:	15	



CENTRE NUMBER:

EXAMINATION NUMBER:

ANSWER SHEET 4.7

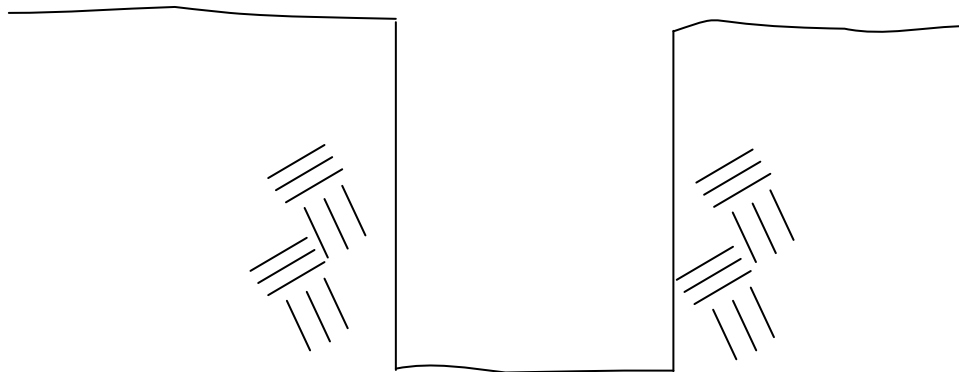

ASSESSMENT CRITERIA		
NO.	MARK	CANDIDATE'S MARK
1	2	
2	4	
3	2	
4	2	
5	2	
TOTAL:	12	



CENTRE NUMBER:										
-----------------------	--	--	--	--	--	--	--	--	--	--

EXAMINATION NUMBER:																			
----------------------------	--	--	--	--	--	--	--	--	--	--	--	--	--	--	--	--	--	--	--

ANSWER SHEET 5.5

	← SUBGRADE
--	------------

ASSESSMENT CRITERIA		
NO.	MARK	CANDIDATE'S MARK
1	1	
2	1	
3	1	
4	1	
5	1	
6	1	
7	3	
TOTAL:	9	



CENTRE NUMBER:

EXAMINATION NUMBER:

ANSWER SHEET 5.6

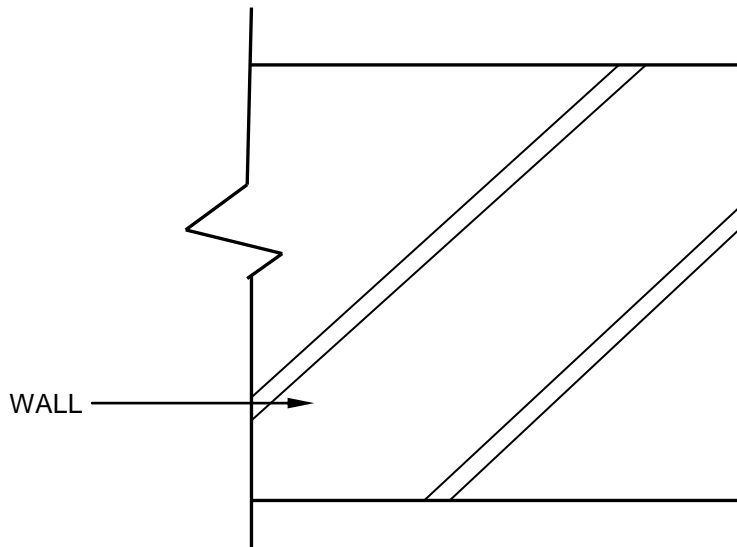

ASSESSMENT CRITERIA		
NO.	MARK	CANDIDATE'S MARK
1	2	
2	2	
3	1	
4	1	
5	1	
6	1	
TOTAL:	8	



