

CENTRE NUMBER: 

--	--	--	--	--	--	--	--

EXAMINATION NUMBER: 

--	--	--	--	--	--	--	--	--	--	--	--	--	--	--	--	--	--	--

**ANSWER SHEET 2**

NO.	QUESTIONS	ANSWERS	MARKS
1.	Name the type of building that is illustrated by FIGURE A.		1
2.	Deduce from the building plan the elevation on which the sink is located.		1
3.	Identify number 1.		1
4.	Why are balusters installed at number 2?		1
5.	What type of material was specified for number 3?		1
6.	Recommend ONE suitable material for number 4.		1
7.	Who is the owner of the proposed dwelling?		1
8.	Identify the number that indicates the downpipe.		1
9.	Name ONE other sanitary fixture, besides a washbasin, that can be installed in the bathroom.		1
10.	Identify number 7.		1
11.	Describe the purpose of number 8.		1
12.	How many fluorescent tubes are indicated in the building?		1
13.	Name the street in which the new building will be erected.		1



**CENTRE NUMBER:**

**EXAMINATION NUMBER:**

14.	What type of finish was specified for the walls?		1
15.	Deduce from the building plan why it was revised.		1
16.	What must be installed to gain access to the first and second floor?		1
17.	Deduce from the building plan who must sign off the building plan.		2
18.	What are the prescribed dimensions for the balusters?		1
19.	How many hinged window openings are indicated on window 2 in the window schedule?		1
20.	Provide a reason for installing solar panels on the roof.		1
21.	The interior door frames are covered with plywood. Draw the symbol for plywood.		2
22.	Draw the symbol for a wall mounted urinal.		2
23.	Describe the top end shape of the baluster.		1



**CENTRE NUMBER:**

**EXAMINATION NUMBER:**

24	Calculate the total height of the building from the finished floor level up to the top of the roof. Give your answer in m.		7
25	Calculate the area of the external wall of the second floor from the top of the floor up to roof height in the west elevation in FIGURE A. Show ALL calculations. Give your answer in m <sup>2</sup> .		7
		<b>TOTAL:</b>	<b>40</b>



<b>CENTRE NUMBER:</b>														
-----------------------	--	--	--	--	--	--	--	--	--	--	--	--	--	--

<b>EXAMINATION NUMBER:</b>																				
----------------------------	--	--	--	--	--	--	--	--	--	--	--	--	--	--	--	--	--	--	--	--

**ANSWER SHEET 3.9**

**TOP VIEW**

--	--	--	--

**FRONT VIEW**

<b>ASSESSMENT CRITERIA</b>		
<b>NO.</b>	<b>MARK</b>	<b>CANDIDATE'S MARK</b>
1	2	
2	3	
<b>TOTAL:</b>	<b>5</b>	



**CENTRE NUMBER:**

**EXAMINATION NUMBER:**

**ANSWER SHEET 4.5**

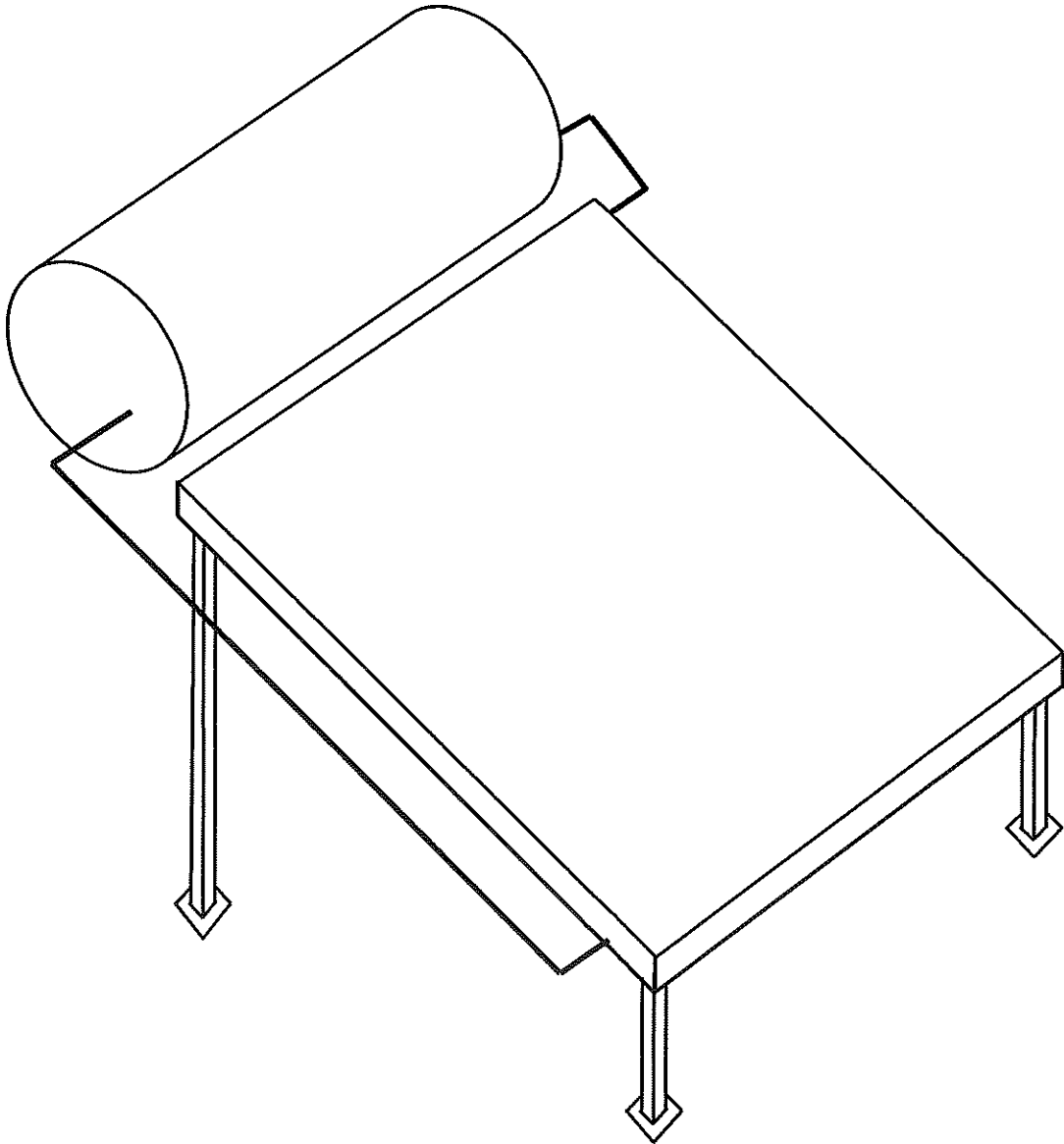

ASSESSMENT CRITERIA		
NO.	MARK	CM
1	4	
2	1	
3	2	
<b>TOTAL:</b>	<b>7</b>	



**CENTRE NUMBER:**

**EXAMINATION NUMBER:**

**ANSWER SHEET 5.6**

ASSESSMENT CRITERIA		
NO.	MARK	CM
1	2	
2	2	
3	1	
4	3	
5	7	
6	1	
7	2	
<b>TOTAL:</b>	<b>18</b>	

